



# ETIBUSBAR

## 60 mm Busbar System

Supports And Connections **938**

NH Fuse-Switch Disconnectors

And Fuse Bases **943**

D Fuse-Switch Disconnectors

And Fuse Bases **947**

Device Adapters **947**



f @ in v  
/etigroup

**ETI**  
SWITCH TO  
A SAFE FUTURE

# ETIBUSBAR **60 mm Busbar System**

## 60 mm busbar system

### Description

With busbar system (Busbar) can be achieved faster assembly and connecting electrical components and higher density of electrical components per unit area. In this way saves time, which is required for assembly and also saving the space required for installation. The main feature of the busbar system is that all components are installed on the busbars, which provide solidness to the components while installing the components in place already provide junction inlet electrical connections. For complete wiring of electrical components is to be performed only wiring branches to consumers. Busbar system is simple in case of need for subsequent extension because the only condition is to extend the copper busbars. ETI's busbar system offers a wide range of items for direct mounting on busbar system, the offer also includes special adapters through which they can connect to other components, which shall be affixed to the mounting plate.

### Fields of use and features

Busbar systems are used wherever we want to achieve high visibility and compact inside electrical cabinets without undue additional wiring. Busbar system can be used in cases of alteration or extension of existing electrical cabinets because the more compact system saves space, or the only way to ensure enough. As a rule, the busbar systems are used in industrial environments, where the structure of electrical cabinets made by functional block and where it should be ensured high visibility electrical components for ease and speed of servicing in the event of failures and downtime.



ETI 60mm busbar system offers:

- /// Short installation time
- /// Less wiring
- /// Standardized dimensions
- /// Easy to install
- /// Flexibility

### Convincing advantages

- /// Wide range of application
- /// Small number of system components
- /// No customized components demand
- /// High flexibility
- /// Innovative and sophisticated solutions
- /// Easy to fit
- /// According to standards IEC 60439-1, VDE 0660 part 500

### Applications

- /// Industry and energetics
- /// Main and Sub-distribution boards
- /// Cable and Wire protection
- /// Motor protection

Examples:

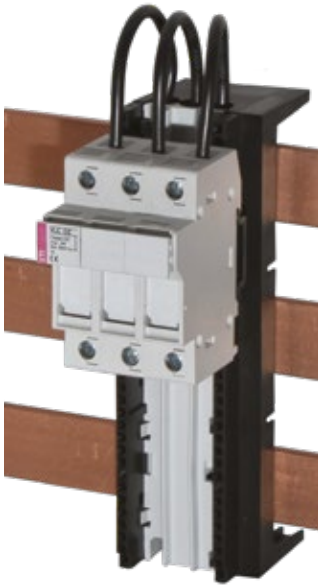

1x DA-60/32/54/1  
1x VLC 10, 3-pole

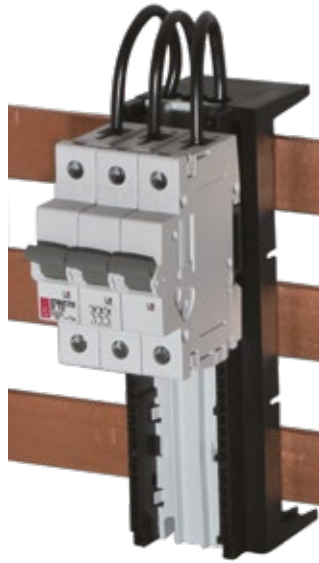

1x DA-60/32/54/1  
1x ETIMAT P10, 32A

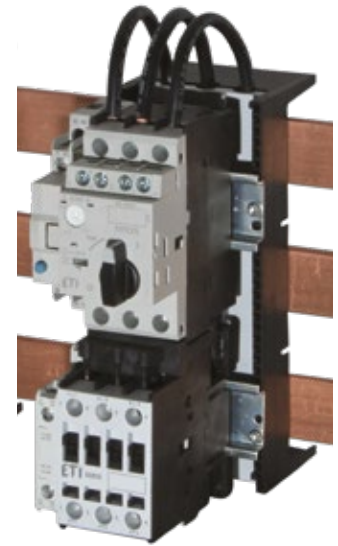

1x DA-60/32/72/2  
1x MPE 25 + UVT + ECCMPE25  
1x CEM 25 + BXCMLE

Example 1

Type	Code No.	Number of Components [pcs]
DVL-60/183	001696050	2
CHVL-60/183	001696152	2
DA-60/250/3/FE-5	001696162	1
EB2S 250/3LF 250A 3p	004671813	1



Example 2

Type	Code No.	Number of Components [pcs]
DA-60/32/54/1	001696081	3
ETIMAT P10, C 32A, 3p	273231109	3
DA-60/250/3/FE-5	001696162	1
EB2S 250/3LF 250A 3p	004671813	1



## Busbar support

### Supports and connections (60mm busbar)

Type	Code No.	Description	
BBS-60/1	001696000	1-pole busbar support for busbars 5-10mm and 20mm or 30mm width	10
BBS-60/3	001696001	3-pole busbar support for busbars 5-10mm and 20mm or 30mm width	10
BBS-60/4	001696002	4-pole busbar support for busbars 5-10mm and 20mm or 30mm width	10
BBS-60/3-A25	001696003	3-pole busbar support for busbars 5-10mm and 20mm or 30mm width with 25mm <sup>2</sup> terminals	5
H5-BBS	001696005	Insertion for busbar height compensation, 5mm	100
L-BBS-60/3	001696006	Lateral cover for busbar holder, 3p	10
L-BBS-60/4	001696007	Lateral cover for busbar holder, 4p	10
S-BBS-60/3	001696008	Side cover for busbar holder (BBS-60/3-A), 3p	10
BBC-60/3	001696009	Busbar cover (3-pole), covering range 27-50mm/piece	50
BBC-60/4	001696010	Busbar cover (4-pole), covering range 27-50mm/piece	50
BBC-1/20	001696011	Busbar cover (1-pole) for single busbar 5-10mm thick and 20mm wide, length 1m	20
BBC-1/30	001696012	Busbar cover (1-pole) for single busbar 5-10mm thick and 30mm wide, length 1m	20
CM-60/250/3	001696013	Connecting module 250A, 3-pole, terminal 1,5 - 70mm <sup>2</sup> connection	1
CM-60/250/4	001696014	Connecting module 250A, 4-pole, terminal 1,5 - 70mm <sup>2</sup> connection	1
CM-60/250/3/120-5	001696015	Connecting module 250A, 3-pole, terminal 16 - 120mm <sup>2</sup> connection using Cu cable or flat Cu busbar 5mm	1
CM-60/250/3/120-10	001696016	Connecting module 250A, 3-pole, terminal 16 - 120mm <sup>2</sup> connection using Cu cable or flat Cu busbar 10mm	1
CM-60/630/3	001696017	Connecting module 630A, 3-pole, terminal 70 - 300mm <sup>2</sup> connection	1
CM-60/630/F/3	001696018	Connecting module 630A, 3-pole, terminal clamping range 11x21mm using flat Cu busbar	1
CT-5/16	001696019	Conductor terminal with clamping range 1,5-16mm <sup>2</sup> for busbar thickness 5mm	50
CT-5/35	001696020	Conductor terminal with clamping range 1,5-35mm <sup>2</sup> for busbar thickness 5mm	15
CT-5/50	001696021	Conductor terminal with clamping range 1,5-50mm <sup>2</sup> for busbar thickness 5mm	15
CT-5/70	001696022	Conductor terminal with clamping range 16-70mm <sup>2</sup> for busbar thickness 5mm	15
CT-5/120	001696023	Conductor terminal with clamping range 16-120mm <sup>2</sup> for busbar thickness 5mm	15
CT-5/185	001696024	Conductor terminal with clamping range 16-185mm <sup>2</sup> for busbar thickness 5mm	15
CT-10/16	001696025	Conductor terminal with clamping range 1,5-16mm <sup>2</sup> for busbar thickness 10mm	50
CT-10/35	001696026	Conductor terminal with clamping range 1,5-35mm <sup>2</sup> for busbar thickness 10mm	15
CT-10/50	001696027	Conductor terminal with clamping range 1,5-50mm <sup>2</sup> for busbar thickness 10mm	15
CT-10/70	001696028	Conductor terminal with clamping range 16-70mm <sup>2</sup> for busbar thickness 10mm	15
CT-10/120	001696029	Conductor terminal with clamping range 16-120mm <sup>2</sup> for busbar thickness 10mm	15
CT-10/185	001696030	Conductor terminal with clamping range 16-185mm <sup>2</sup> for busbar thickness 10mm	15
PT-30/34x10	001696031	Plate terminal for busbars up to 30mm width, clamping range 34x34x10mm	3
PT-40/34x10	001696150	Plate terminal for busbars up to 40mm width, clamping range 34x34x10mm	3
PT-50/34x10	001696151	Plate terminal for busbars up to 50mm width, clamping range 34x34x10mm	3
BBCH-60/144	001696032	Universal cover of 3-pole busbars 5-10mm, covering width 144mm (ex. cover for conductor terminals type CT- ...)	1
BBCH-60/84	001696033	Universal cover of 3-pole busbars 5-10mm, covering width 84mm (ex. cover for conductor terminals type CT- ...)	1



BBS-60/3



BBS-60/3-A25



H5-BBS

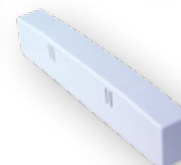

L-BBS



S-BBS-60-3



BBC-60/3

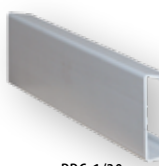

BBC-1/30



CM-60/250



CM-60/630



CT-5, 10/...



PT-30/34x10



BBCH-60/144



BC-20x5-30x10

BBS-60/... can be adjusted to 20m or 30mm busbar width and 5-10 mm thickness.

CT terminals can accept only Cu conductors.

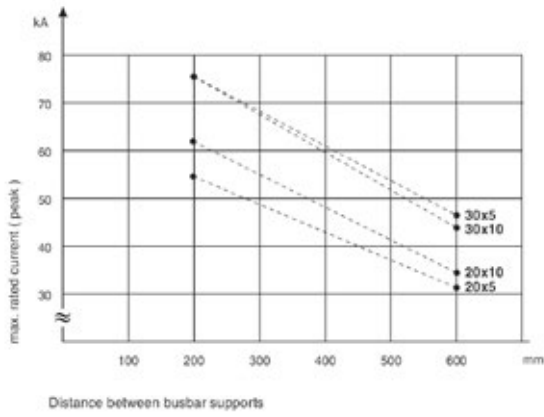

Dimensions

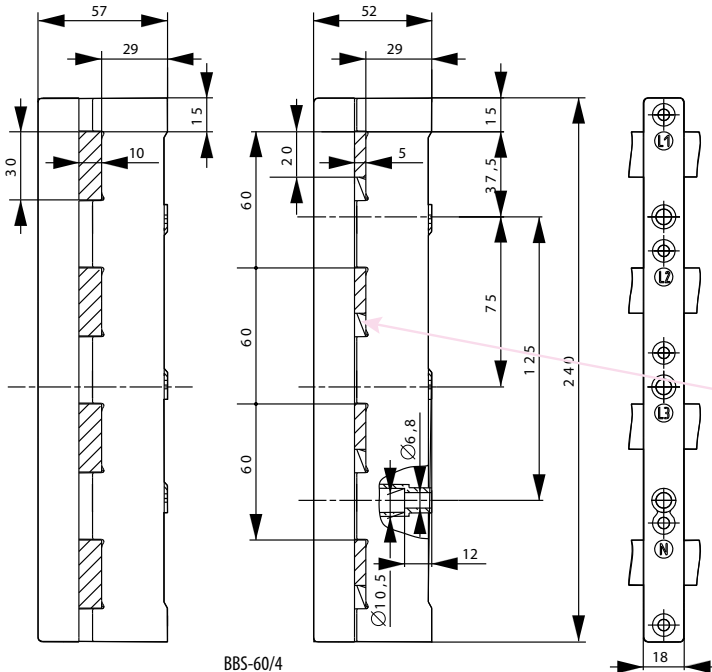
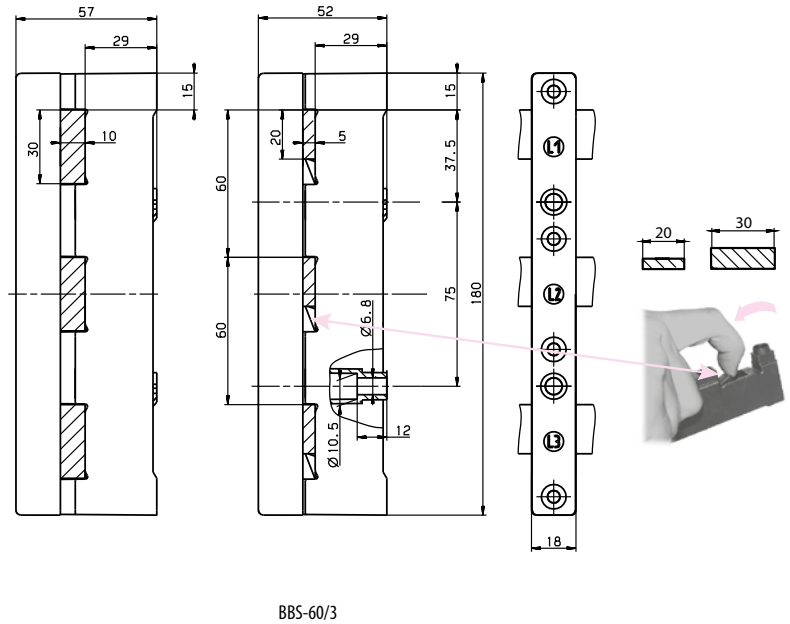
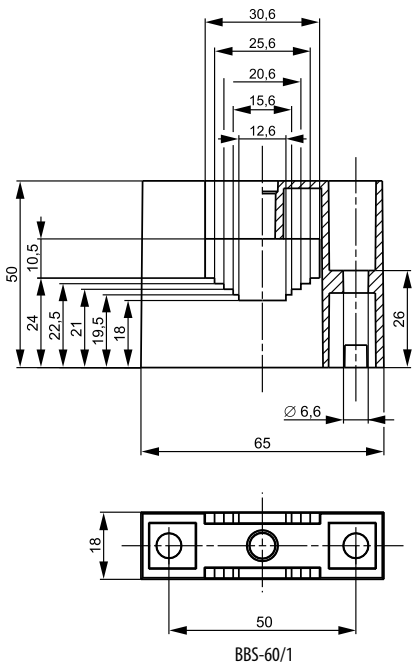

# ETIBUSBAR / 60 mm Busbar System

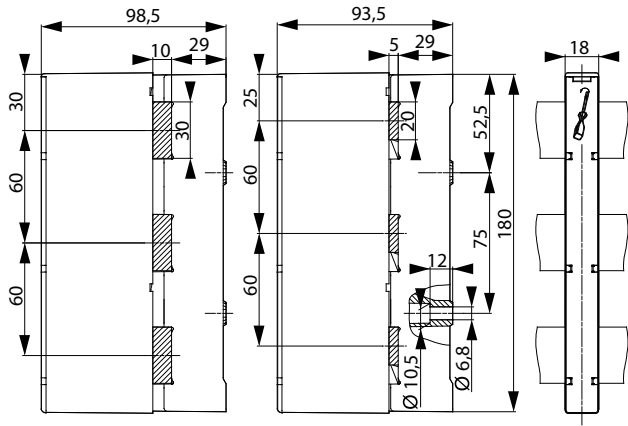

BBS-60/3-A16 (A25)

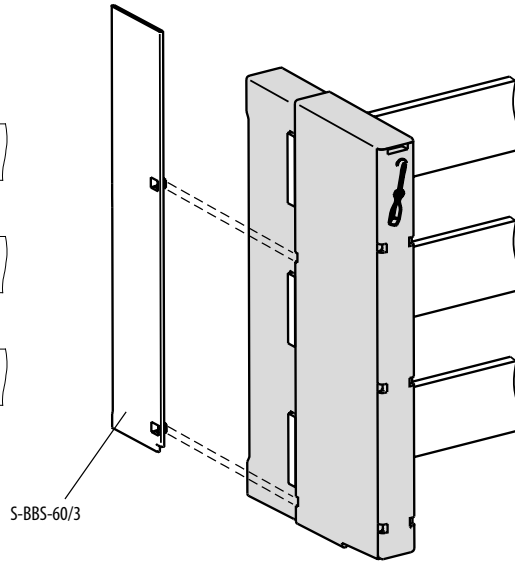

S-BBS-60/3

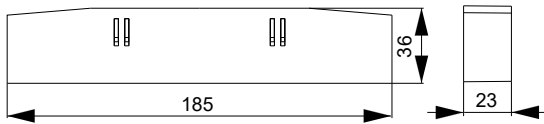

L-BBS-60/3

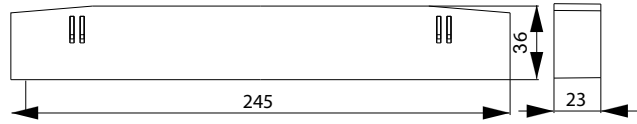

L-BBS-60/4

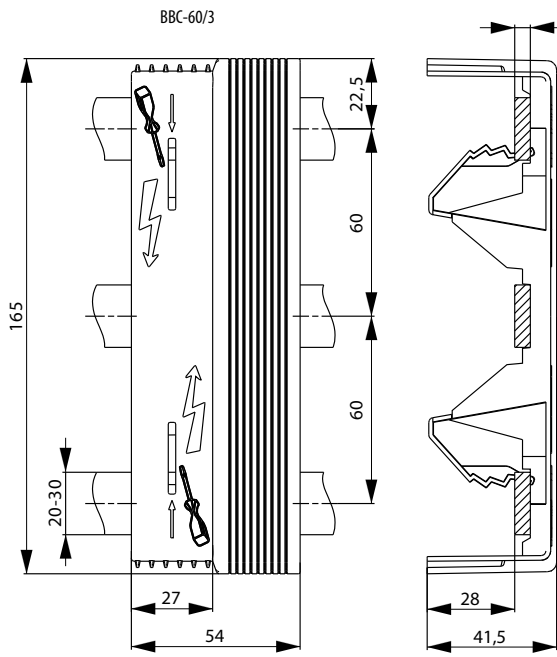

BBC-60/3

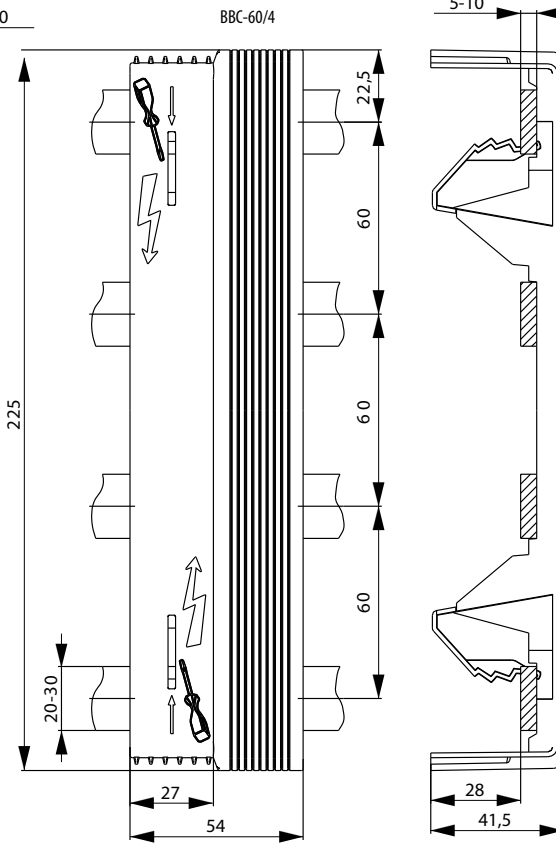

BBC-60/4



BBC-1/20, BBC-1/30

BBC-1/20	21	20x5 / 20x10
BBC-1/30	31	30x5 / 30x10

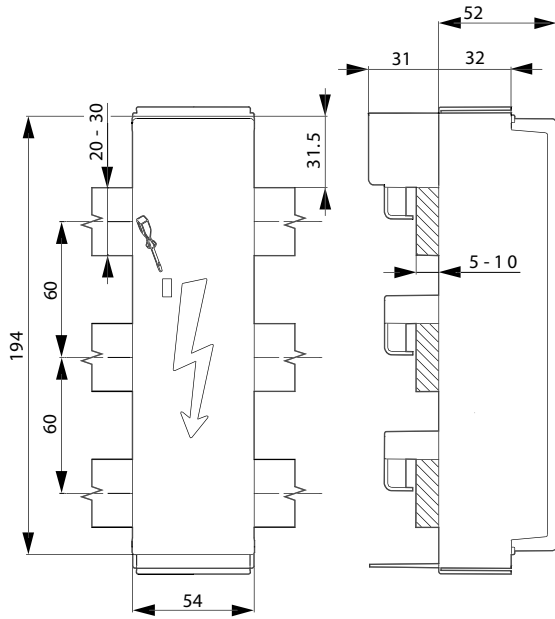

CM-60/250/3

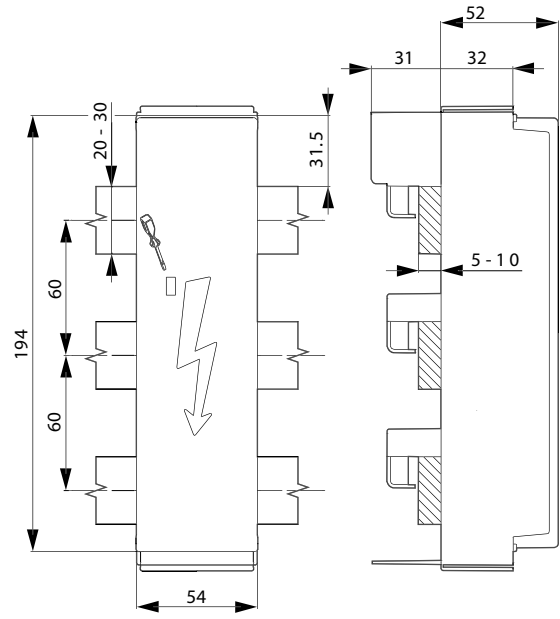

CM-60/250/4

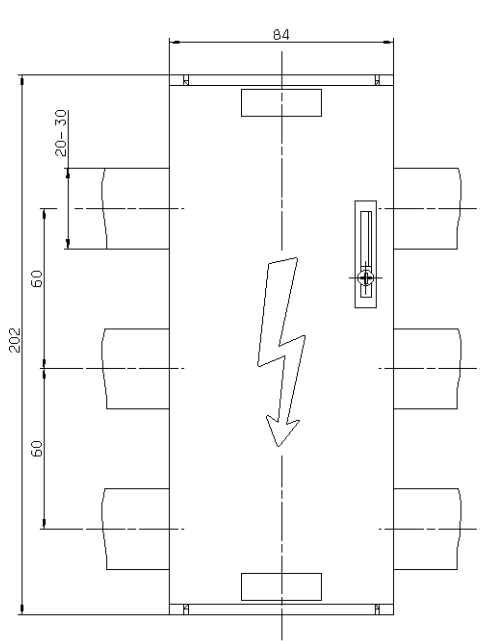

CM-60/250/3/120-5/10

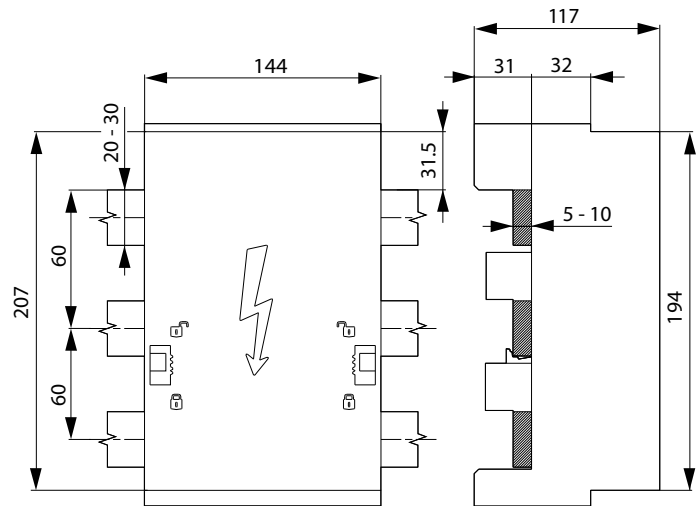
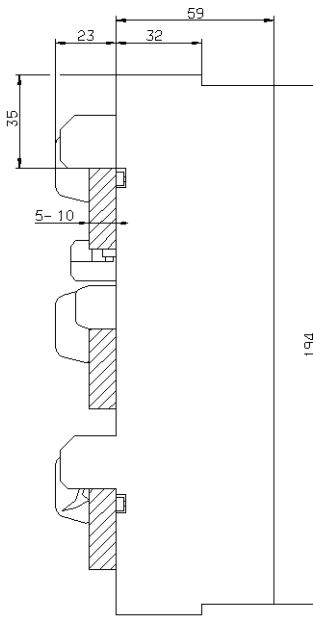

CM-60/630/3

# ETIBUSBAR / 60 mm Busbar System

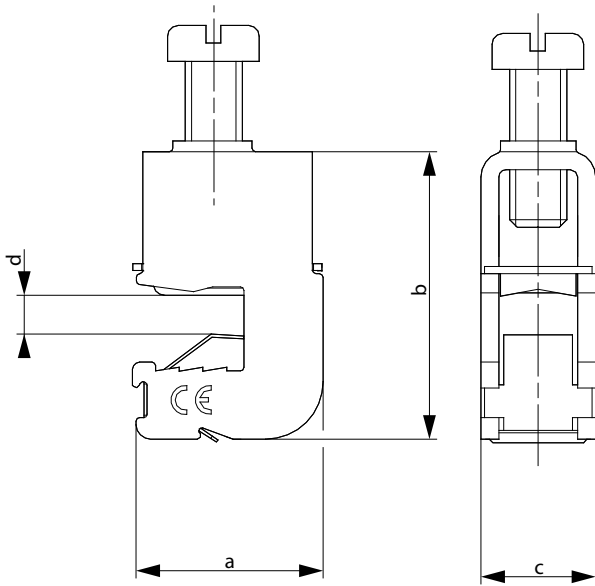

CT-...

	d (Busbar thickness)	a	b	c
CT-5/16	5	25,5	26,5	12
CT-5/35		26,5	31,5	16
CT-5/50		26,5	35	16
CT-5/70		28	39	20,5
CT-5/120		29	46	23
CT-5/185		29	49	28,5
CT-10/16	10	25,5	31,5	12
CT-10/35		26,5	36	16
CT-10/50		26,5	40	16
CT-10/70		28	39	20,5
CT-10/120		29	51	23
CT-10/185		29	53	28,5

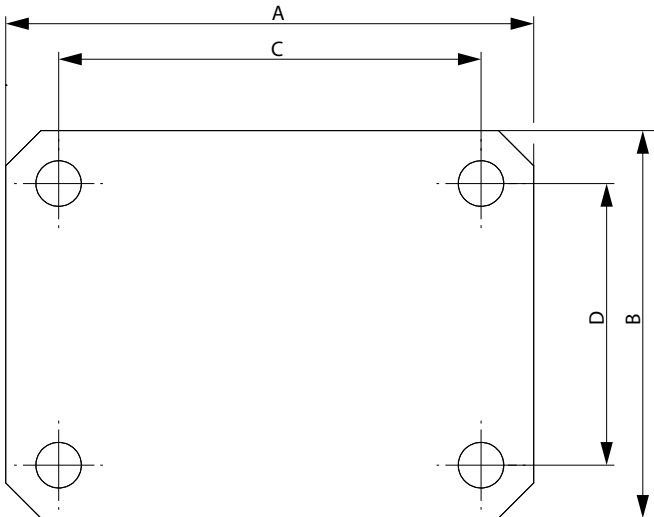

	A	B	C	D
00169031	55	55	40	40
00169150	65	55	50	40
00169151	75	55	60	40

PT-30/34x10

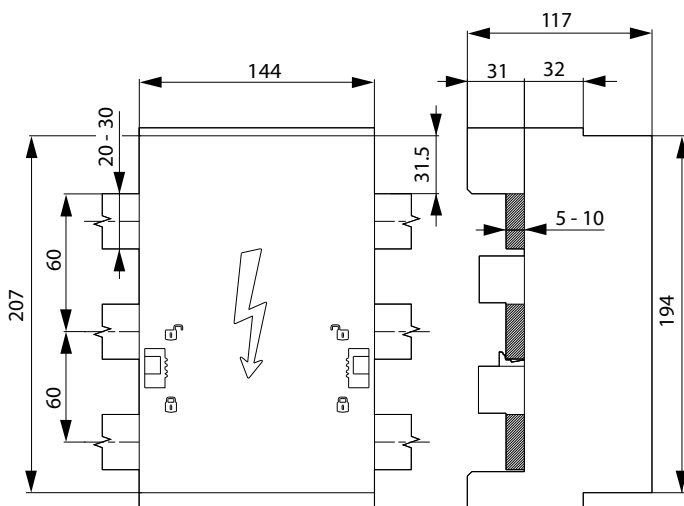

BBCH-60/144

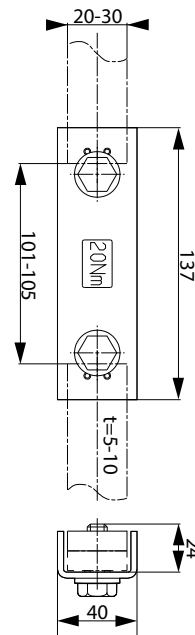

BC-20x5-30x10



## NV/NH horizontal fuse-switch disconnectors KVL for busbar mounting

### Uniform cover cutout

KVL - horizontal fuse-switch disconnectors with different sizes can be combined together and form uniform cover cutout. The new assortment contains four cover support levels at 32, 60, 70 and 90 mm above the upper of busbar. KVL fuse-switch disconnectors can be mounted on busbars (for baseplates and DIN rails see chapter NV/NH).

- Available with 1- and 3-pole versions
- Four sizes: size 00, size 1, size 2, size 3
- Use with NV/NH Fuse-links 000, 00, 1, 2, 3

### Busbar mounting

KVL-00 to KVL-3 can be mounted onto 60mm busbar systems - no drilling required



### Uniform cover cutout for all sizes disconnectors

Changeable installation depth by 4 different field supporting surfaces (32mm, 60mm, 70mm, 90mm)

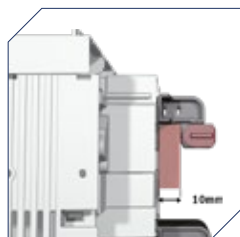

### Easy adjustments

- adjustment to 5mm or 10mm thick bars
- simple modification of cable terminal from bottom side to top side

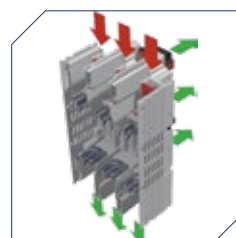

### Area-saving:

- integrated feeding terminal
- Busbar supply and safe outgoing cable outlet
- Busbar supports up to 20mm width, 19mm height max.

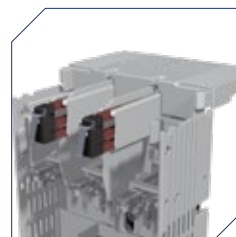

### Retrofittable switch position indicator

- Dual monitoring in each unit
- Separate circuits function
- Wide range of applications due to high switching capacity 10/3A (resistive/ind.) AC250V

# ETIBUSBAR / 60 mm Busbar System

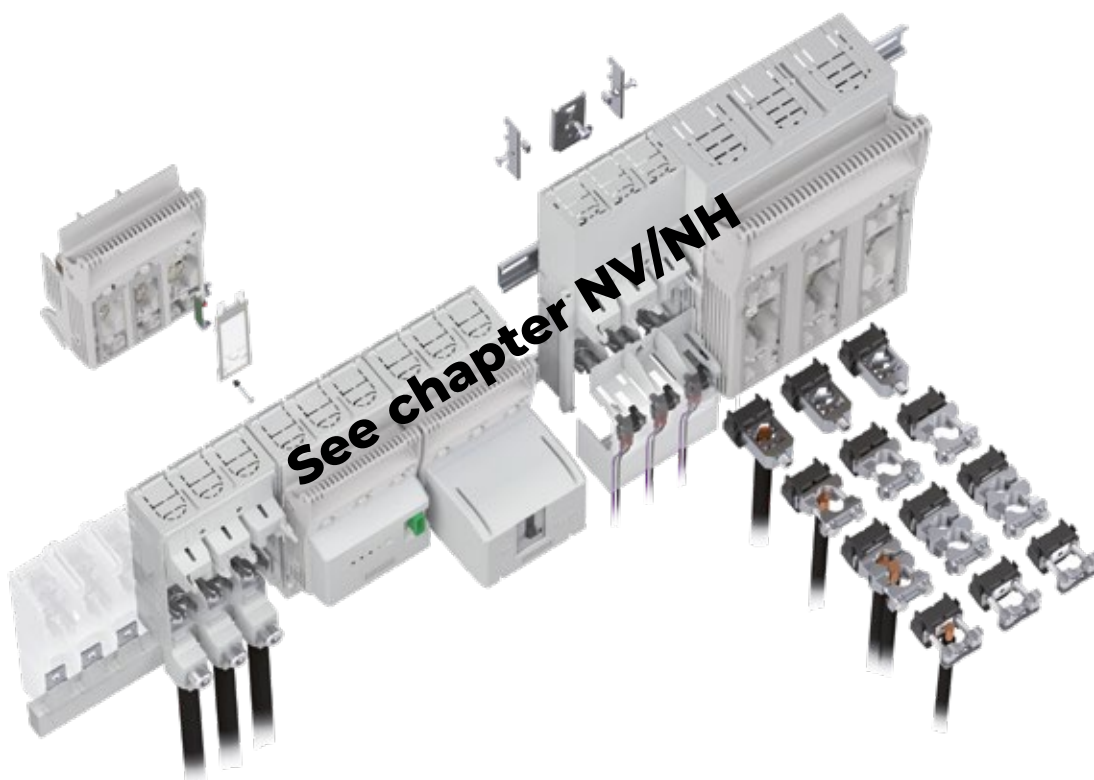
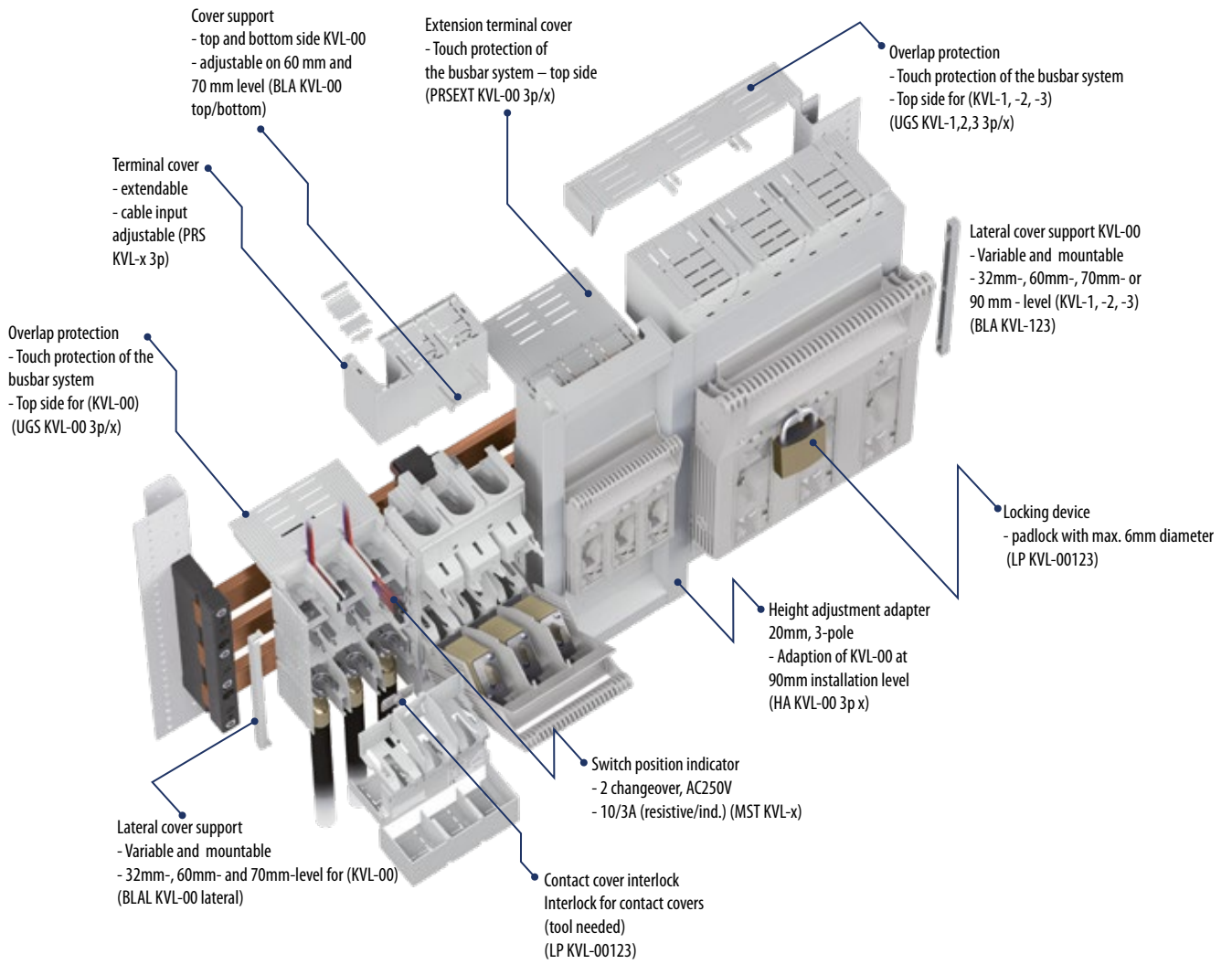

**3-pole, 60mm busbar, thickness 5 mm or 10 mm**

Size	Code No.	Type	kg	Box
000	001690915	KVL-B-000 3p F50 Bottom	0,58	1
	001690916	KVL-B-000 3p F50 Top	0,58	1
00	001690910	KVL-B-00 3p M8-M8	0,9	1
	001690911	KVL-B-00 3p BC95-BC95	0,92	1
1	001690912	KVL-B-1 3p M10-M10	2,14	1
2	001690913	KVL-B-2 3p M10-M10	3,53	1
3	001690914	KVL-B-3 3p M10-M10	4,13	1

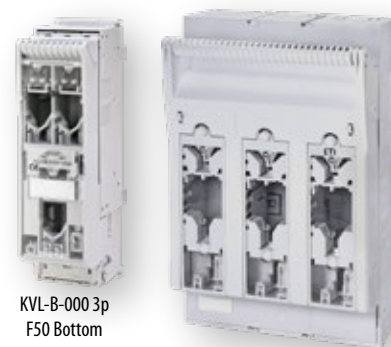

KVL-B-000 3p F50 Bottom

**3-pole, 60mm busbar, Integrated Feeding Terminal**

Size	Code No.	Type	Feeding side - Line - I1	Load side I2	I1	I2	kg	Box
00	001690920	KVL-B/FT-00 3p M8-M8	top/bottom	top/bottom	400	160	1,05	1
1	001690922	KVL-B/FT-1 3p M10-M10	top/bottom	top/bottom	500	250	2,39	1
2	001690923	KVL-B/FT-2 3p M10-M10 TOP	bottom	top	800	400	3,9	1
	001690924	KVL-B/FT-2 3p M10-M10 BOTTOM	top	bottom	800	400	3,9	1
3	001690926	KVL-B/FT-3 3p M10-M10 TOP	top/bottom	top/bottom	1000	630	4,45	1

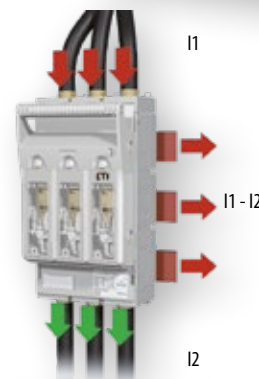

**1-pole busbar**

Size	Code No.	Type	Fixation	kg	Box
00	001690930	KVL-B/SF-00 1p M8-M8	screw fixation	0,35	2
	001690931	KVL-B/CF-00 1p M8-M8	clamp fixation	0,39	2
1	001690932	KVL-B/SF-1 1p M10-M10	screw fixation	0,98	1
2-3	001690933	KVL-B/SF-3 1p M10-M10	screw fixation	1,59	1

DO NOT USE WITH 3-pole 60 mm busbar system !!!



!!! ONLY FOR 1-POLE BUSBAR

**Accessories for KVL busbar 60 mm**

Type	Code No.	Description	Box*
HA KVL-00 3p T/B 340-370	001690980	Height adjusting adapter, 70 to 90mm, 3-pole, System size 340-370mm, top + bottom, size 00	1
HA KVL-00 3p T/B 300	001690981	Height adjusting adapter, 70 to 90mm, 3-pole, System size 300mm, top + bottom, size 00	1
HA KVL-00 3p L/R 340-370	001690982	Height adjusting adapter, 70 to 90mm, 3-pole, System size 340-370mm, right + left, size 00	1
HA KVL-00 3p L/R 300	001690983	Height adjusting adapter, 70 to 90mm, 3-pole, System size 300mm, right + left, size 00	1
PRS KVL-000 3p TOP	001691071	Terminal cover for top side	2
PRS KVL-000 3p BOTTOM	001691072	Terminal cover for bottom side	2
PRSEXT KVL-00 3p/34-39	001690984	Terminal cover extension, 3-pole, h1 = 39 or 34mm, size 00, *	2
PRSEXT KVL-00 3p/32	001690985	Terminal cover extension, 3-pole, h1 = 32mm, size 00, *	2
UGS KVL-000 3p/34-39	001691073	Overlap protector for busbar systems, 39 or 34mm,	10
UGS KVL-00 3p/34-39	001690986	Overlap protector for busbar systems, h1 = 39 or 34mm, for terminal F, S00, P00, R95, size 00	2
UGS KVL-00 3p/32	001690987	Overlap protector for busbar systems, h1 = 32mm, for terminal F, S00, P00, R95, size 00	2
UGS KVL-00 3p/R95T/34-39	001690988	Overlap protector for busbar systems, h1 = 39 or 34mm, for terminal R95T, size 00	2
UGS KVL-00 3p/R95T/32	001690989	Overlap protector for busbar systems, h1 = 32mm, for terminal R95T, size 00	2
UGS KVL-1 3p/34-39	001690990	Overlap protector for busbar systems, h1 = 39 or 34mm, size 1	2
UGS KVL-1 3p/32	001690991	Overlap protector for busbar systems, h1 = 32mm, size 1	2
UGS KVL-2 3p/39-34	001690992	Overlap protector for busbar systems, h1 = 39 or 34mm, size 2	2
UGS KVL-2 3p/32	001690993	Overlap protector for busbar systems, h1 = 32mm, size 2	2
UGS KVL-3 3p/39-34	001690994	Overlap protector for busbar systems, h1 = 39 or 34mm, size 3	2
UGS KVL-3 3p/32	001690995	Overlap protector for busbar systems, h1 = 32mm, size 3	2
BLAL KVL-000 lateral	001691074	Cover support	10
BLA KVL-00 top/bottom	001690961	Cover support, top or bottom side, level 60mm, 70mm, size 00	10
BLAL KVL-00 lateral	001690962	Cover support, lateral, level 32mm, 60mm, 70mm, size 00	10
BLA KVL-123	001690963	Cover support, top or bottom side, lateral, level 32mm, 60mm, 70mm, size 1, 2, 3	10

\* min order [pcs]

h1 = Distance top edge busbar to base plate



PRS\_KVL-000\_top-bottom

UGS KVL-000 3p/34-39

BLAL KVL-000 lateral

BLA\_KVL-00\_top-bottom

BLAL\_KVL

HA KVL-00 3p T/B 300

## Accessories for KVL

Type	Code No.	Description	 *
SP KVL00	001692701	Clip terminal, 1,5 – 70 mm <sup>2</sup> Cu	3
SP KVL1	001692702	Clip terminal, 25– 150 mm <sup>2</sup> Cu	3
SP KVL2	001692703	Clip terminal, 25– 240 mm <sup>2</sup> Cu	3
SP KVL3	001692704	Clip terminal, 11x21 mm <sup>2</sup> Cu	3
SP KVL00 P1	001692760	Prism clamp, 10 – 70 mm <sup>2</sup> Al/Cu	3
SP KVL1 P1	001692761	Prism clamp, 70 – 150 mm <sup>2</sup> Al/Cu	3
SP KVL2 P1	001692762	Prism clamp, 120 – 240 mm <sup>2</sup> Al/Cu	3
SP KVL3 P1	001692763	Prism clamp, 120 – 300 mm <sup>2</sup> Al/Cu	3
SP KVL1 P2	001692764	Prism clamp for 2-conductors connection, 2x70 – 95 mm <sup>2</sup> Al/Cu	3
SP KVL2 P2	001692765	Prism clamp for 2-conductors connection, 2x120 – 150 mm <sup>2</sup> Al/Cu	3
SP KVL3 P2	001692766	Prism clamp for 2-conductors connection, 2x120 – 240 mm <sup>2</sup> Al/Cu	3
SP HVL 4a D2	001692767	Direct terminal clamp for 2-conductors connection, 2x120– 300mm <sup>2</sup> Al/Cu	1
SP HVL 4a D3	001692768	Direct terminal clamp for 3-conductors connection, 3x95 – 150 mm <sup>2</sup> Al/Cu	1
SP HVL 4a D4	001692769	Direct terminal clamp for 4-conductors connection, 4x95 – 150 mm <sup>2</sup> Al/Cu	1
SP KVL-1 V	001690940	Frame clamp, 35-150mm <sup>2</sup> Al/Cu	3
SP KVL-23 V	001690941	Frame clamp, 95-300mm <sup>2</sup> Al/Cu	3
MTB KVL00 2x25/1x16/M8	001690978	Terminal block with multiple wire connections	3
MTB KVL00 4x10/M8	001690979	Terminal block with multiple wire connections	3
MST KVL-000 3p	001691070	Switch position indicator	1
MST KVL-00 1p	001690947	Switch position indicator, 1-pole, size 00, **	1
MST KVL-00 3p	001690948	Switch position indicator, 3-pole, size 00, **	1
MST KVL-123 1p/2p/3p	001690949	Switch position indicator, 1/2/3 -pole, size 1, 2, 3, **	1
MFM KVL-00 1p/2p/3p	001690950	Mechanical fuse monitor, size 00, **	3
MFM KVL-123 1p/2p/3p	001690951	Mechanical fuse monitor, size 1, 2, 3, **, ***	3
PRS KVL-00 3p L	001690952	Terminal cover, 3-pole, variable to open, Length 66mm, size 00	2
PRS KVL-00 3p S	001690953	Terminal cover, 3-pole, variable to open, Length 36mm, size 00	2
PRS KVL-1 3p	001690954	Terminal cover, 3-pole, variable to open, Length 42mm, size 1	2
PRS KVL-2 3p	001690955	Terminal cover, 3-pole, variable to open, Length 42mm, size 2	2
PRS KVL-3 3p	001690956	Terminal cover, 3-pole, variable to open, Length 42mm, size 3	2
PRS KVL-00 1p L	001690957	Terminal cover, 1-pole, variable to open, Length 66mm, size 00	2
PRS KVL-00 1p S	001690958	Terminal cover, 1-pole, variable to open, Length 36mm, size 00	2
PRS KVL-1 1p	001690959	Terminal cover, 1-pole, variable to open, Length 42mm, size 1	2
PRS KVL-3 1p	001690960	Terminal cover, 1-pole, variable to open, Length 42mm, size 3	2
EFMU KVL-00 3p	001690966	Electronic fuse monitoring unit, 3-pole, size 00, ****	1
EFMU KVL-1 3p	001690967	Electronic fuse monitoring unit, 3-pole, size 1, ****	1
EFMU KVL-2 3p	001690968	Electronic fuse monitoring unit, 3-pole, size 2, ****	1
EFMU KVL-3 3p	001690969	Electronic fuse monitoring unit, 3-pole, size 3, ****	1
MPF MU KVL-00 3p	001690974	Elektromechanical fuse monitoring unit (AM), 3-pole, size 00, ****	1
MPF MU KVL-1 3p	001690975	Elektromechanical fuse monitoring unit (AM), 3-pole, size 1, ****	1
MPF MU KVL-2 3p	001690976	Elektromechanical fuse monitoring unit (AM), 3-pole, size 2, ****	1
MPF MU KVL-3 3p	001690977	Elektromechanical fuse monitoring unit (AM), 3-pole, size 3, ****	1
LP KVL-00123	001690972	Interlock device, locking with padlock, diameter 6mm max., size 00, 1, 2, 3	10
IC KVL-00123	001690973	Contact cover interlock, only be operated by tool, size 00-3	10

\* min order [pcs]

\*\* 1 Changeover, AC250V, 10/3A (ohmic/ind.)

\*\*\* Only in combination with ETI fuse-links with striker-pin; not in combination with frame-clamp or 2-wire-prism clamp.

\*\*\*\* For monitoring of fuse-links with live gripping lugs



PRS KVL-00 1p



PRS KVL-00 1p S



SP KVL... P2



SP KVL-1 V



MST KVL-000 3p



CK KVL-00 2p/4p



IC KVL-00123



LP KVL-00123

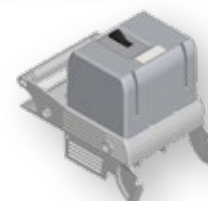

MPF MU



EFMU



PRS KVL-00 3p L



PRSEXT KVL-00 3p/34-39



UGS KVL-(1 or 2 or 3) 3p/x



UGS KVL-00 3p/34-39

**Device adapters for 60 mm busbar**

Type	Code No.	Description	
DA-60/250/3/FE-5	001696162	Adapter for MCCB - ETIBREAK EB2 250 and EB2S 250	1
DA-60/250/4/FE-5	001696163	Adapter for MCCB - ETIBREAK EB2 250 and EB2S 250	1



MCCB adapter

**Note:**

When ordering D-type fuse-bases and fuse-switch disconnectors, please also order fuse carriers and gauge pieces additionally. See D (page 745) and D0 (page 765) chapters of the catalogue.

**D fuse-switch disconnector and fuse bases for 60mm busbar**

Type	Code No.	Description	
DVL-60/183	001696050	Fuse-switch disconnector for fuses D02	1
CHVL-60/183	001696152	CH-type fuse-switch disconnector	1
PTV-B D02-27/183-5	001696051	D02-type-fuse-bases 3-pole for push-in gauge ring, width 27mm	10
PTV-B DII-45/273-5	001696052	DII-type-fuse-bases 3-pole for push-in gauge ring, width 45mm	1
PTV-B DIII-54/333-5	001696053	DIII-type-fuse-bases 3-pole for push-in gauge ring, width 54mm	10
PTV-B DII-45/273S-5	001696054	DII type-fuse-bases 3-pole for push-in gauge ring, width 45mm	10
PTV-B DIII-54/333S-5	001696055	DIII type-fuse-bases 3-pole for push-in gauge ring, width 54mm	10
C-PTV-B D02-27/183/195	001696056	Protection cover width 27mm, height 195mm	10
C-PTV-B D02-36/183/195	001696057	Protection cover width 36mm, height 195mm	10
C-PTV-B DII-45/273/195	001696058	Protection cover width 45mm, height 195mm	10
C-PTV-B DIII-54/333/195	001696059	Protection cover width 54mm, height 195mm	10
C-PTV-B D02-27/183/230	001696060	Protection cover width 27mm, height 230mm	10
C-PTV-B D02-36/183/230	001696061	Protection cover width 36mm, height 230mm	10
C-PTV-B DII-45/273/230	001696062	Protection cover width 45mm, height 230mm	10
C-PTV-B DIII-54/333/230	001696063	Protection cover width 54mm, height 230mm	10
CL-PTV-B D/195	001696064	Side protection cover width 195 (for C-PTV-B ... /195)	1
CL-PTV-B D/230	001696065	Side protection cover width 230 (za C-PTV-B ... /230)	10
RPH-195	001696066	Protection cover	15
HP-DVL	001696067	Protection cover for DVL and CHVL, TOP/BOTTOM	2
RTP-D02-27/183	001696068	Reach-through protection, face top and bottom, 27mm width	20
RTP-D02-36/183	001696069	Reach-through protection, face top and bottom, 36mm width	20
RTP-DII-45/273	001696070	Reach-through protection, face top and bottom, 45mm width	10
RTP-DIII-54/333	001696071	Reach-through protection, face top and bottom, 54mm width	10
PRS-D02-27/183	001696072	Overreaching protection, face top and bottom, 27mm width	20
PRS-D02-36/183	001696073	Overreaching protection, face top and bottom, 36mm width	20
PRS-DII-45/273	001696074	Overreaching protection, face top and bottom, 45mm width	10
PRS-DIII-54/333	001696075	Overreaching protection, face top and bottom, 54mm width	10
RTP-RL/230	001696076	Reach-through protection lateral right and left	20
PRS-DVL	001696077	D-strips spacer module	10
HAS	001696111	Compensation piece for busbar thickness (to adapt busbar components to fit 10mm or 5mm busbar thickness)	100

\*HAS is compensation piece which is intent to use for adaptation for example fuse-bases or fuse-switch disconnector from 10mm busbar thickness to 5mm busbar thickness. Each phase pole needs one compensation piece.



DVL-60/183  
CHVL-60/183

PTV-B ...

C-PTV-B ... /195

C-PTV-B ... /230

CL-PTV-B D/195

RPH-195

RTP-D ...

PRS-D ...

RTP-RL/230

PSR\_DVL

PRS-D ...

HAS

Horizontal fuse-switch disconnecter type KVL size 000, 00, 1, 2, 3 (60mm busbar)

Technical data (in accordance with IEC/EN 60947-3)

Size			000			00					
Technical Characteristics											
Rated operational voltage	Ue	V	500 a.c.	690 a.c.	400 a.c.	500 a.c.	690 a.c.	800 a.c.	1000 a.c.	250 d.c.	1000 d.c.
Rated operational current	Ie	A	125	80	160	160	160	63	160	160	160
Conv. free air thermal current with fuse-links, *	Ith	A	125		160						
Conv. free air thermal current with solid-links, *	Ith	A	250		210						
Rated frequency	f	Hz	40-60								
Rated insulation voltage	Ui	V	800 a.c.								
Total power loss (without fuse)	Pv	W	12		1P - 3 W, 3P - 9 W						
Power loss at 80% Ith (without fuse-links), **	Pv	W	8		1P - 1,9 W, 3P - 5,8 W						
Rated impulse withstand voltage	Uimp	kV	6		8						
Utilisation category***			AC-22B	AC-21B	AC-23B	AC-22B	AC-21B	AC-21B	AC-20B	DC-22B	DC-20B
Rated conditional short-circuit current, ***, ****		kA	80 (500 a.c.)		120 (500 a.c.), 100 (690 a.c.), 10 (800 a.c.), 35 (250 d.c.)						
Rated short-time withstand current	Icw	kA	5/1s								
Fuse links											
Size - DIN VDE 0636-2	-	-	000			000/00					
Max. rated current (gG)	In	A	125	80	160	160	160	63	160	160	160
Max. permissible power loss per fuse link	Pa	W	12								
Cable terminal											
Flat terminal-Screw									M8		
Tightening torque	Ma	Nm							12-15		
Clip terminal, Clamping cross-section		mm <sup>2</sup>							(SP KVL00) Round conductor: 1,5-70 Cu, Strip conductor: 6 x 9 x 0,8 Cu		
Tightening torque	Ma	Nm							2,6		
Prism Clamp, Clamping cross-section		mm <sup>2</sup>							(SP KVL00 P1); 10-70 Al/Cu, 35-95 Al/Cu		
Tightening torque	Ma	Nm							2,6		
Prism Clamp, Clamping cross-section		mm <sup>2</sup>									
Tightening torque	Ma	Nm									
Frame clamp, Clamping cross-section		mm <sup>2</sup>	1,5-50 Cu		1,5-95 Al/Cu, (Al 95: max. 125A)*****						
Torque	Ma	Nm							4,5		
Degree of Protection, front side device											
Front cover close	-	-							IP20		
Front cover open	-	-							IP10		
With clamp- and lateral cover	-	-	IP30			IP2XC					
Operating condition											
Ambient temperature *****	Tamb	°C							-25 ... +55		
Operating condition	-	-							Continuous operation		
Mounting	-	-							vertical, horizontal		
Altitude	-	m							≤ 2000		
Pollution degree	-	-	2		3						
Overvoltage category	-	-	III		IV						
Endurance											
Mechanical cycles			1400			1600					
Electrical cycles			200								

\* Mounting of several units in low voltage switchgear-combinations, please think about rated diversity factors acc. to DIN EN 61439.

\*\* Reference value for replacement of devices acc. to DIN EN 61439-1 clause 10.10.4.2.

\*\*\* minimum distance to earthed, conductive parts: Lateral: 20mm/Above: 50mm

\*\*\*\* a) Lateral: 50mm/Above: 100mm

\*\*\*\*\* Type tested with NH fuse-links characteristic gG

\*\*\*\*\* 35°C Normal temperature, at 55°C with reduced operating current

**Technical data (in accordance with IEC/EN 60947-3)**

Size	0					1					
Technical Characteristics											
Rated operational voltage	Ue	V	400 AC	500 AC	690 AC	250 DC	400 AC	500 AC	690 AC	250 DC	440 DC#
Rated operational current	Ie	A	160	160	160	160	250	250	250	250	250
Conv. free air thermal current with fuse-links, *	Ith	A	160				250				
Conv. free air thermal current with solid-links, *	Ith	A	On request				On request				
Rated frequency	f	Hz	40-60	40-60	40-60	/	40-60	40-60	40-60	/	/
Rated insulation voltage	Ui	V	800 AC				800 AC				
Total power loss (without fuse)	Pv	W	1P - 5 W, 3P - 14 W				1P - 7 W, 3P - 22 W				
Power loss at 80% Ith (without fuse-links), **	Pv	W	1P - 3 W, 3P - 9 W				1P - 4,7 W, 3P - 14,1 W				
Rated impulse withstand voltage	Uimp	kV	8				8				
Utilisation category***			AC-23B	AC-22B	AC-21B	DC-22B	AC-23B	AC-22B	AC-21B	DC-22B	DC-21B
Rated conditional short-circuit current, ***, ****		kA	120 (500V), 100 (690V)				120 (500V), 100 (690V)				
Rated short-time withstand current	Icw	kA	5/1s				8,6/1s				
Fuse links											
Size - DIN VDE 0636-2	-	-	000/00				1				
Max. rated current (gG)	In	A	160	160	160	160	250	250	250	250	250
Max. permissible power loss per fuse link	Pa	W	12				23				
Cable terminal											
Flat terminal-Screw			M8				M10				
Tightening torque	Ma	Nm	12-15				30-35				
Clip terminal, Clamping cross-section		mm <sup>2</sup>	Round conductor: 1,5-70 Cu, Laminated copper bar: 6 x 9 x 0,8 Cu				Round conductor: 2,5-150 Cu, Laminated copper bar: 6 x 16 x 0,8 Cu				
Tightening torque	Ma	Nm	2,6				9,5				
Prism Clamp, Clamping cross-section		mm <sup>2</sup>	(SP KVL00 P1); 10-70 Al/Cu, 35-95 Al/Cu				(SP KVL1 P1); 10-150 Al/Cu				
Tightening torque	Ma	Nm	(SP KVL00 P1); 2,6				(SP KVL1 P1); 4,5				
Prism Clamp, Clamping cross-section		mm <sup>2</sup>					(SP KVL1 P2); 2 x (10-150) Al/Cu				
Tightening torque	Ma	Nm					(SP KVL1 P2); 4,5				
Frame clamp, Clamping cross-section		mm <sup>2</sup>	1,5-95 Al/Cu, (Al 95: max. 125A)				35-150 Al/Cu				
Torque	Ma	Nm	4,5				12				
Degree of Protection, front side device											
Front cover close	-	-	IP20				IP20				
Front cover open	-	-	IP10				IP10				
With clamp- and lateral cover	-	-	IP2XC				IP2XC				
Operating condition											
Ambient temperature *****	Tamb	°C	-25 ... +55				-25 ... +55				
Operating condition	-	-					Continuous operation				
Mounting	-	-					vertical, horizontal				
Altitude	-	m					≤ 2000				
Pollution degree	-	-					3				
Overvoltage category	-	-	III				III				

\* Mounting of several units in low voltage switchgear-combinations, please think about rated diversity factors acc. to DIN EN 61439.

\*\* Reference value for replacement of devices acc. to DIN EN 61439-1 clause 10.10.4.2.

\*\*\* minimum distance to earthed, conductive parts: Lateral: 20mm/Above: 50mm

\*\*\*\* a) Lateral: 50mm/Above: 100mm

\*\*\*\*\* Type tested with NH fuse-links characteristic gG

\*\*\*\*\* 35°C Normal temperature, at 55°C with reduced operating current

# 3p version only

## Technical data (in accordance with IEC/EN 60947-3)

Size	2						3					
Technical Characteristics												
Rated operational voltage	Ue	V	400 AC	500 AC	690 AC	250 DC	440 DC	400 AC	500 AC	690 AC	250 DC	440 DC#
Rated operational current	Ie	A	400	400	400	400	400	630	630	630	630	630
Conv. free air thermal current with fuse-links, *	Ith	A	400					630				
Conv. free air thermal current with solid-links, *	Ith	A	On request					On request				
Rated frequency	f	Hz	40-60	40-60	40-60	/	/	40-60	40-60	40-60	/	/
Rated insulation voltage	Ui	V	1000 AC					1000 AC				
Total power loss (without fuse)	Pv	W	1P - 12 W, 3P - 36 W					1P - 29 W, 3P - 86 W				
Power loss at 80% Ith (without fuse-links), **	Pv	W	1P - 7,7 W, 3P - 23 W					1P - 18,3 W, 3P - 55 W				
Rated impulse withstand voltage	Uimp	kV	8					8				
Utilisation category***			AC-23B	AC-22B	AC-21B	DC-22B	DC-22B	AC-23B	AC-22B	AC-21B	DC-22B	DC-22B
Rated conditional short-circuit current, ***, ****		kA	120 (500V), 100 (690V)					120 (500V), 100 (690V)				
Rated short-time withstand current	Icw	kA	15/1s					15/1s				
Fuse links												
Size - DIN VDE 0636-2	-	-	2					3				
Max. rated current (gG)	In	A	400	400	400	400	400	630	630	630	630	630
Max. permissible power loss per fuse link	Pa	W	34					48				
Cable terminal												
Flat terminal-Screw			M10					M10 / M12				
Tightening torque	Ma	Nm	30-35					30-35				
Clip terminal, Clamping cross-section		mm <sup>2</sup>	Round conductor: 25-150 Cu, Laminated copper bar: 10 x 16 x 0,8 Cu					Laminated copper bar: 11 x 21 x 1 Cu				
Tightening torque	Ma	Nm	23					23				
Prism Clamp, Clamping cross-section		mm <sup>2</sup>	(SP KVL2 P1); 120-240 Al/Cu					(SP KVL3 P1); 120-300 Al/Cu				
Tightening torque	Ma	Nm	(SP KVL2 P1); 11					(SP KVL3 P1); 11				
Prism Clamp, Clamping cross-section		mm <sup>2</sup>	(SP KVL2 P2); 2 x (120-150) Al/Cu					(SP KVL3 P2); 2 x (120-240) Al/Cu				
Tightening torque	Ma	Nm	(SP KVL2 P2); 11					(SP KVL3 P2); 11				
Frame clamp, Clamping cross-section		mm <sup>2</sup>	95 - 300 Al/Cu					95-300 Al/Cu				
Torque	Ma	Nm	20					20				
Degree of Protection, front side device												
Front cover close	-	-	IP20					IP20				
Front cover open	-	-	IP10					IP10				
With clamp- and lateral cover	-	-	IP2XC					IP2XC				
Operating condition												
Ambient temperature *****	Tamb	°C	-25 ... +55					-25 ... +55				
Operating condition	-	-	Continuous operation					Continuous operation				
Mounting	-	-	vertical, horizontal					vertical, horizontal				
Altitude	-	m	≤ 2000					≤ 2000				
Pollution degree	-	-	3					3				
Overvoltage category	-	-	III					III				

\* Mounting of several units in low voltage switchgear-combinations, please think about rated diversity factors acc. to DIN EN 61439.

\*\* Reference value for replacement of devices acc. to DIN EN 61439-1 clause 10.10.4.2.

\*\*\* minimum distance to earthed, conductive parts: Lateral: 20mm/Above: 50mm

\*\*\*\* a) Lateral: 50mm/Above: 100mm

\*\*\*\*\* Type tested with NH fuse-links characteristic gG

\*\*\*\*\* 35°C Normal temperature, at 55°C with reduced operating current

# 3p version only





Load cable terminal at topside

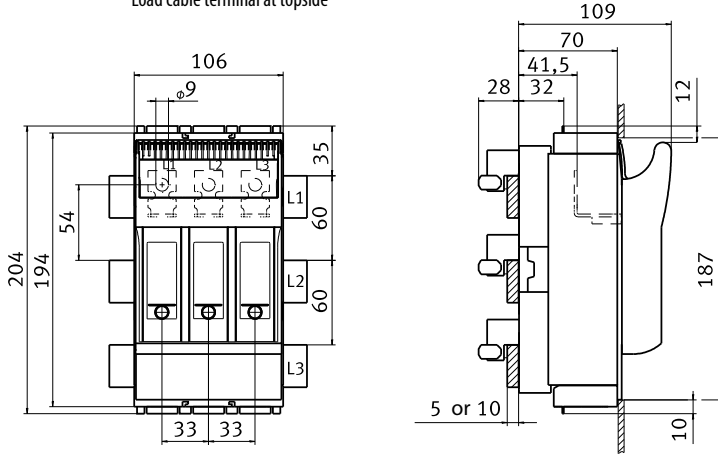

Load cable terminal at bottom side

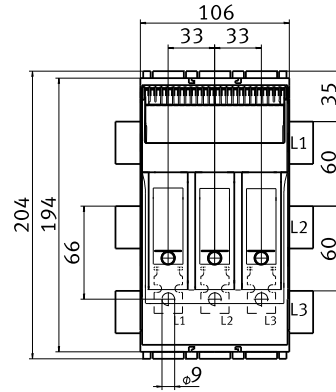

KVL-B-00 3p M8-M8
KVL-B-00 3p BC95-BC95
KVL-B/FT-00 3p M8-M8

Load cable terminal at bottom side

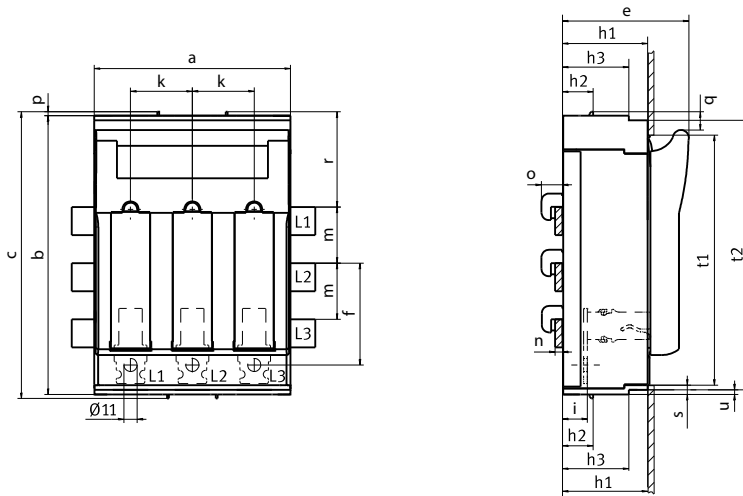

	a	b	c	e	f	h1	h2	h3	i	k	l	m	n	o	p	q	r	s	t1	t2	u
KVL-B-1 3p M10-M10	184	298	306	117	98	70	32	-	25,5	58	Ø10,5	60	4-10	25	4	19	102	5	272	-	-
KVL-B/FT-1 3p M10-M10 TOP																					
KVL-B/FT-1 3p M10-M10 BOTTOM																					
KVL-B-2 3p M10-M10	210	298	306	135	109	90	32	70	26,5	66	Ø14	60	4-10	25	4	19	102	10	268	289	5
KVL-B/FT-2 3p M10-M10 TOP																					
KVL-B/FT-2 3p M10-M10 BOTTOM																					
KVL-B-3 3p M10-M10	250	298	306	143	109	90	32	70	26,5	82	Ø14	60	4-10	25	4	19	102	10	268	289	5

# ETIBUSBAR / 60 mm Busbar System

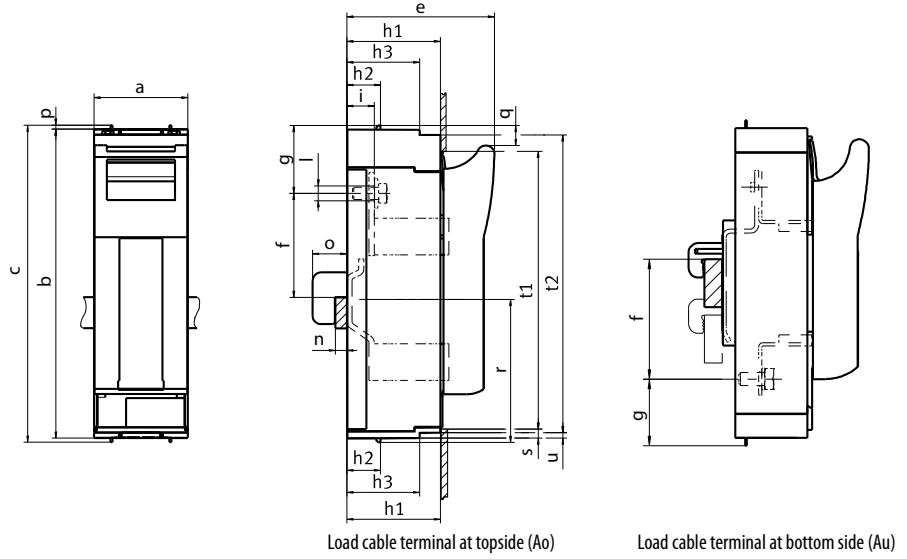

	a	b	c	e	f-Ao	f-Au	g-Ao	g-Au	h1	h2	i	l	n	o	p	q	r	s	t1
KVL-B/SF-00 1p M8-M8	50	195	204	92	45,50,55 ... 75	75,70,65 ... 45	42	42	53	15	24,5	∅9	4-10	22	4,5	12	102	5	187
KVL-B/CF-00 1p M8-M8																			

Load cable terminal at topside (Ao)

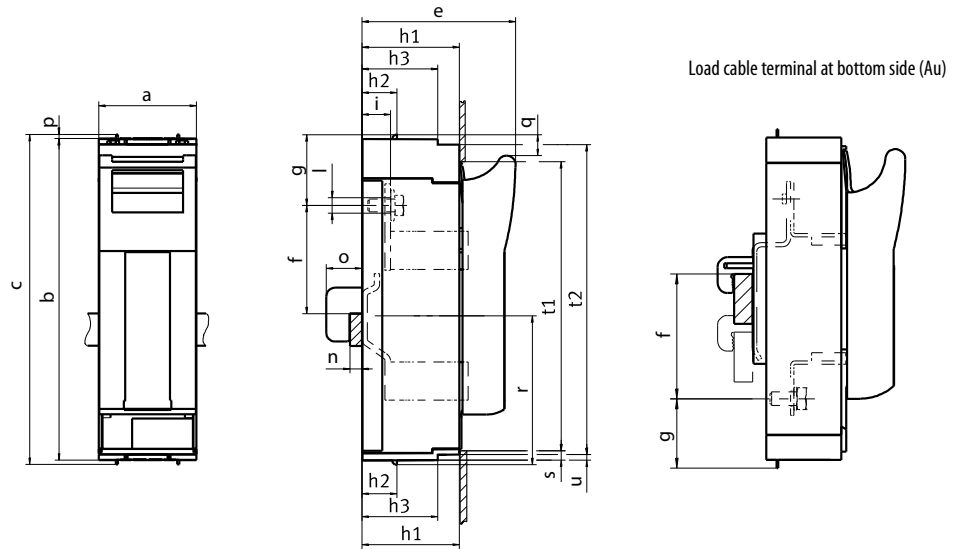

	a	b	c	e	f-Ao	f-Au	g-Ao	g-Au	h1	h2	h3	i	l	n	o	p	q	r	s	t1	t2	u
KVL-B/SF-1 1p M10-M10	69	298	306	117	93	93	76	44	70	32	-	25,5	∅10,5	5-10	33	4	19	138	5	272	-	-
KVL-B/SF-3 1p M10-M10	91	298	306	143	100	104	66	36	90	32	70	26,5	∅14	5-10	33	4	19	138	10	268	289	5

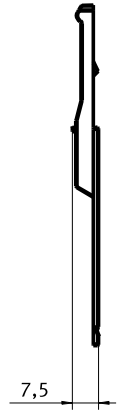
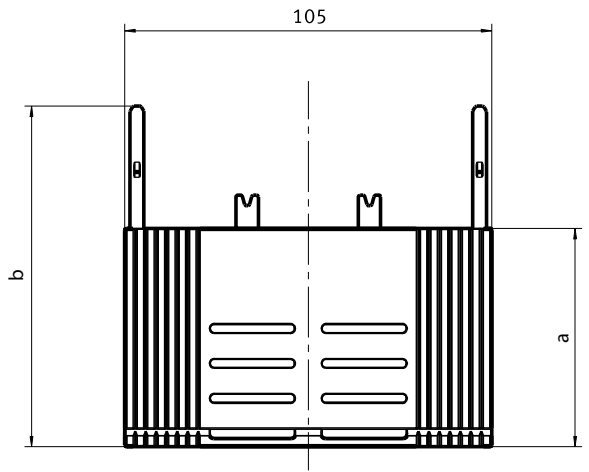
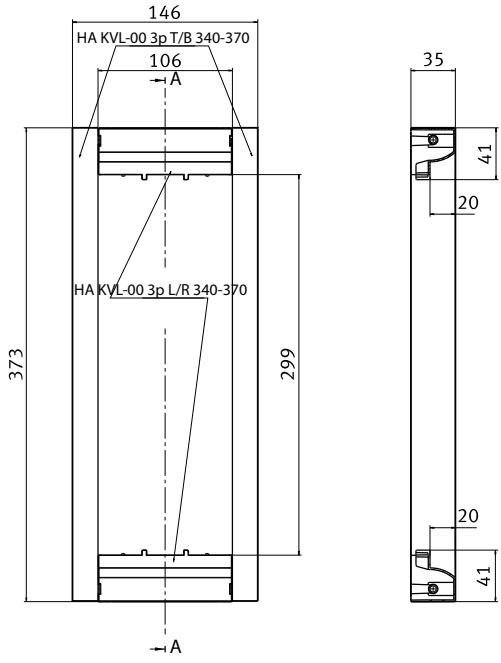

	a	b
PRSEXT KVL-00 3p/34-39	62,5	97,5
PRSEXT KVL-00 3p/32	55,5	90,5

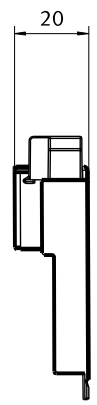
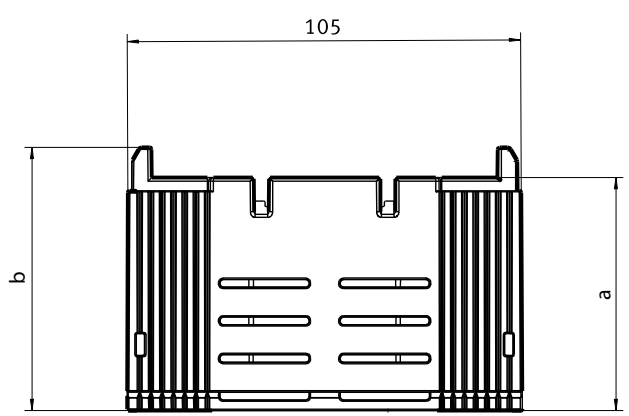

	a	b
UGS KVL-00 3p/34-39	62	70
UGS KVL-00 3p/32	55	63

# ETIBUSBAR / 60 mm Busbar System

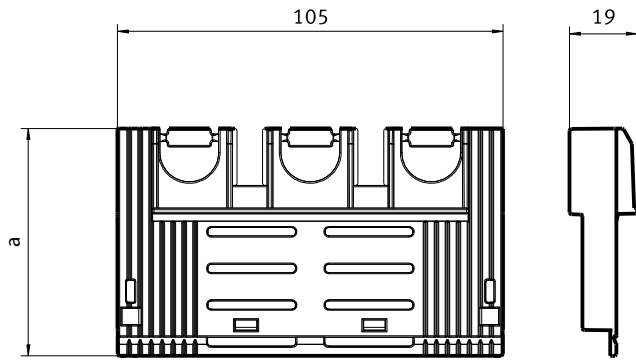

	a
UGS KVL-00 3p/R95T/34-39	62
UGS KVL-00 3p/R95T/32	55

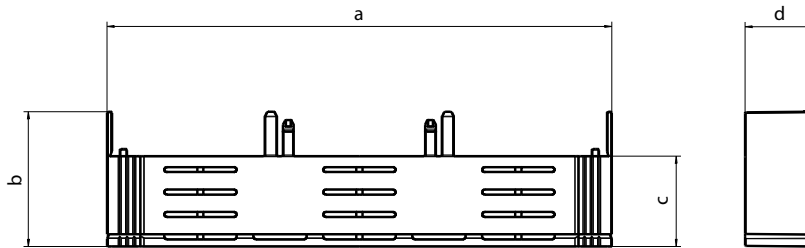

	a	b	c	d
UGS KVL-1 3p/32	184	51,5	30,5	16
UGS KVL-1 3p/34-39	184	58,5	37,5	16
UGS KVL-2 3p/32	210	49	30,5	28,5
UGS KVL-2 3p/39-34	210	56	37,5	28,5
UGS KVL-3 3p/32	250	49	30,5	28,5
UGS KVL-3 3p/39-34	250	56	37,5	28,5

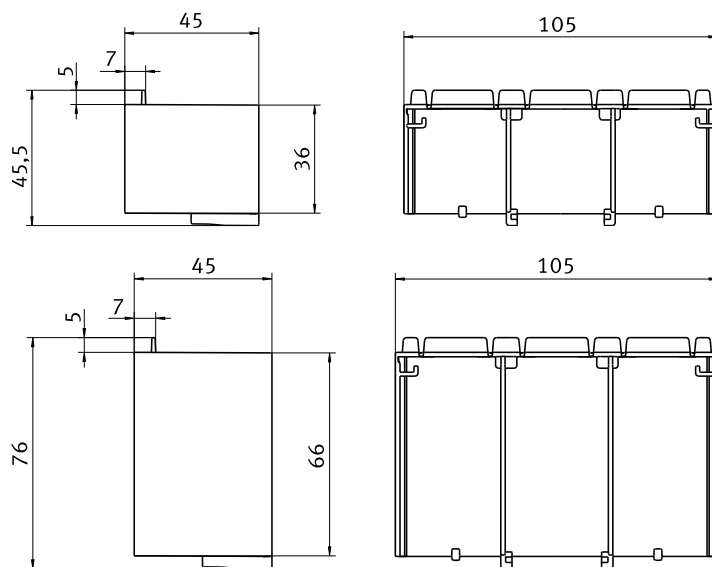

PRS KVL-00 3p S
PRS KVL-00 3p L

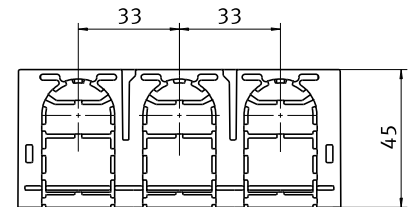

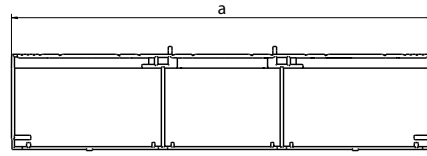
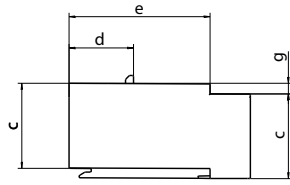

	a	b	c	d	e	f	g
PRS KVL-1 3p	184	70	42	32	-	58	-
PRS KVL-2 3p	210	90	42	32	70	66	5
PRS KVL-3 3p	250	90	42	32	70	82	5

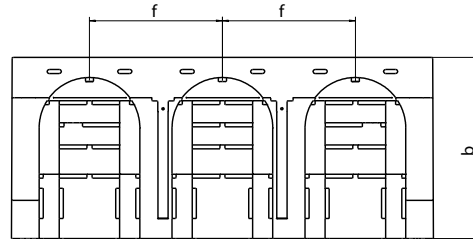

PRS KVL-00 1p L

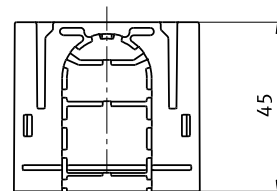
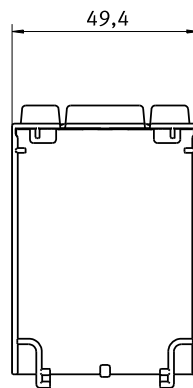
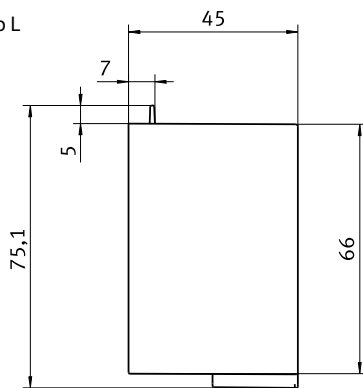

PRS KVL-00 1p S

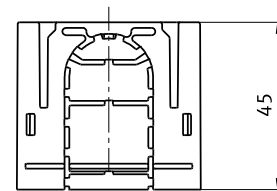
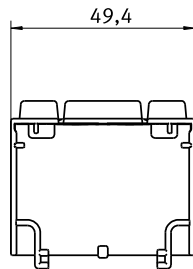
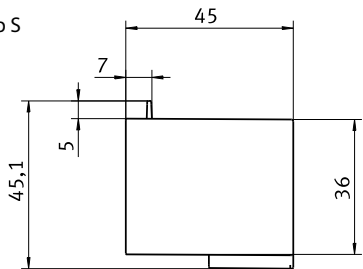

PRS KVL-1 1p

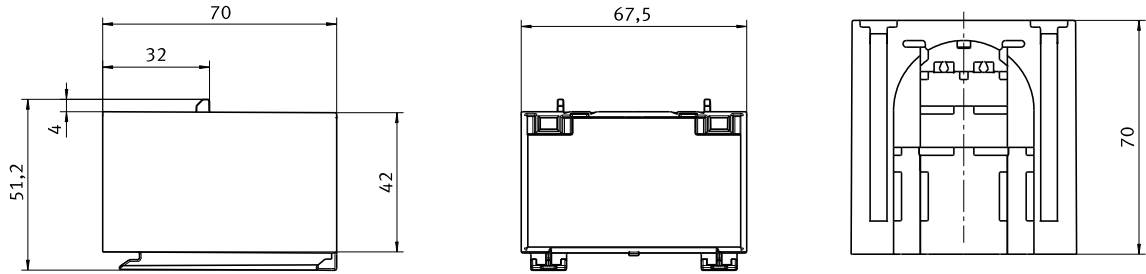

PRS KVL-3 1p

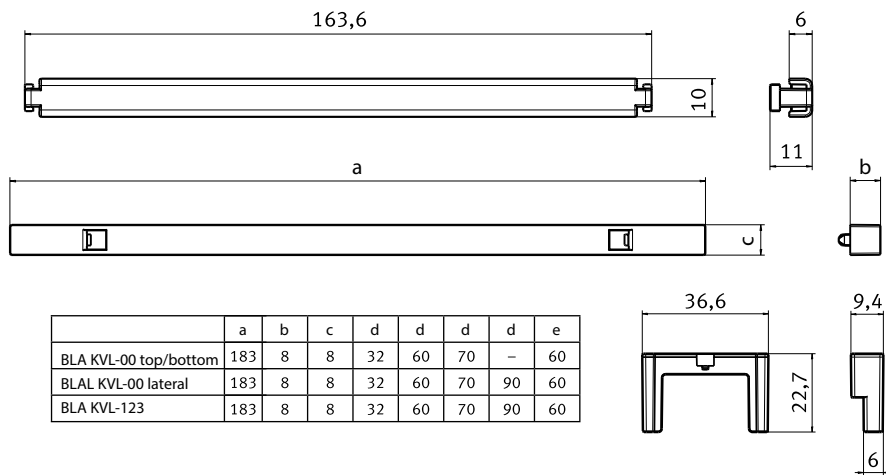
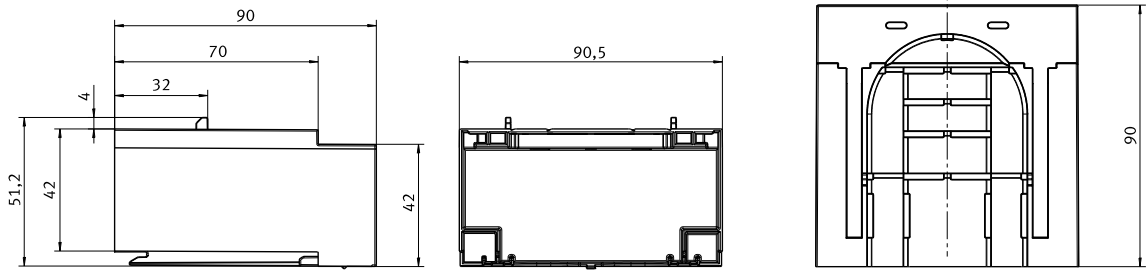

	a	b	c	d	d	d	d	e
BLA KVL-00 top/bottom	183	8	8	32	60	70	-	60
BLAL KVL-00 lateral	183	8	8	32	60	70	90	60
BLA KVL-123	183	8	8	32	60	70	90	60

**Technical data - Electronic fuse monitoring unit EFMU KVL**

Technical Characteristics			
Rated operational voltage	Ue	V	AC400-500 (+/-10%)
Power supply			Self-powered
Input power		VA	1,5
Overvoltage category			230/400 V : III , (4kV) 500 V : II , (4kV)
Rated frequency	f	Hz	50-60
Input resistance			>1k Ohm/V
Output channels			
Relay output			1NC/1NO
Maximum voltage		V	AC250/DC24
Maximum switching current		A	1
General data			
Operation indicator			1 LED green
Alarm indicator			3 LED (F1, F2, F3) red
Functional test			Test key for relay + LEDs
EMC			IEC 61000-4-5/IEC 61000-4-4
Degree of protection			IP 3X
Operating conditions			
Ambient temperature	Tamb	°C	-5 ... +55

No single detection of parallel connected fuses!

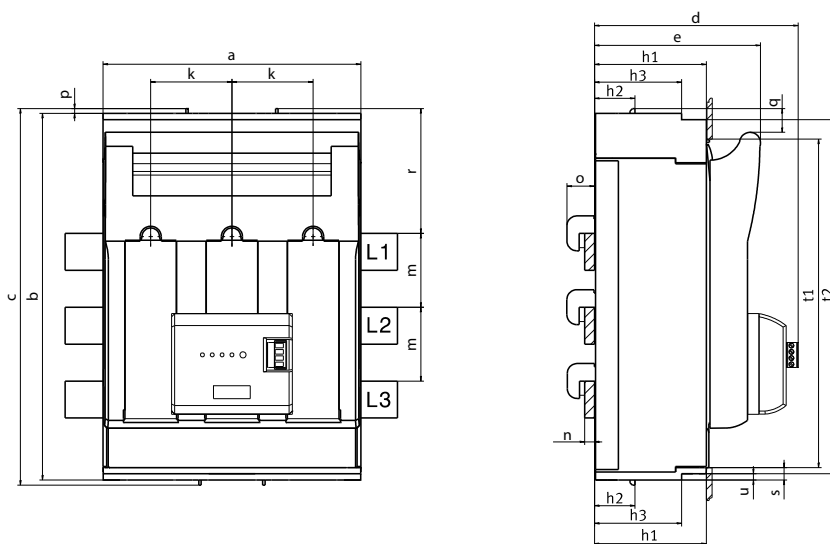

	a	b	c	d	e	h1	h2	h3	k	m	n	o	p	q	r	s	t1	t2	u	
KVL-B-1 3p M10-M10 + EFMU KVL-1 3p																				
KVL-B/FT-1 3p M10-M10 TOP + EFMU KVL-1 3p	184	298	306	148	117	70	32	-	58	60	4-10	25	4	19	102	5	272	-	-	
KVL-B/FT-1 3p M10-M10 BOTTOM + EFMU KVL-1 3p																				
KVL-B-2 3p M10-M10 + EFMU KVL-2 3p																				
KVL-B/FT-2 3p M10-M10 TOP + EFMU KVL-2 3p	210	298	306	165	135	90	32	70	66	60	4-10	25	4	19	102	10	268	289	5	
KVL-B/FT-2 3p M10-M10 BOTTOM + EFMU KVL-2 3p																				
KVL-B-3 3p M10-M10 + EFMU KVL-3 3p	250	298	306	173	143	90	32	70	82	60	4-10	25	4	19	102	10	268	289	5	

## Technical data - Electromechanical fuse monitoring unit MPFMU KVL

Technical Characteristics			
Rated operational voltage	Ue	V	AC24...690 DC24...250
Rated short-circuit breaking capacity	Icn	kA	100
Overvoltage category			230/400V : III (4kV) 500V : II (4kV)
Output channels			
Relay output			1NC/1NO
Maximum voltage		V	AC230/DC24
Maximum switching current		A	2,5A...AC-12 / 1A...DC-13

No single detection of parallel connected fuses!

### Safety notes

May not be used for safety monitoring in feeders with power control units where, in the event of a fault, it is possible for a DC feedback of >300V (or >600V where 3 current paths are connected in parallel) to occur. If equipment has to be disconnected on the load side of the fuses to be monitored, make sure that no parasitic voltages can arise in the circuit-breaker that is connected in parallel with the fuse-monitoring device.

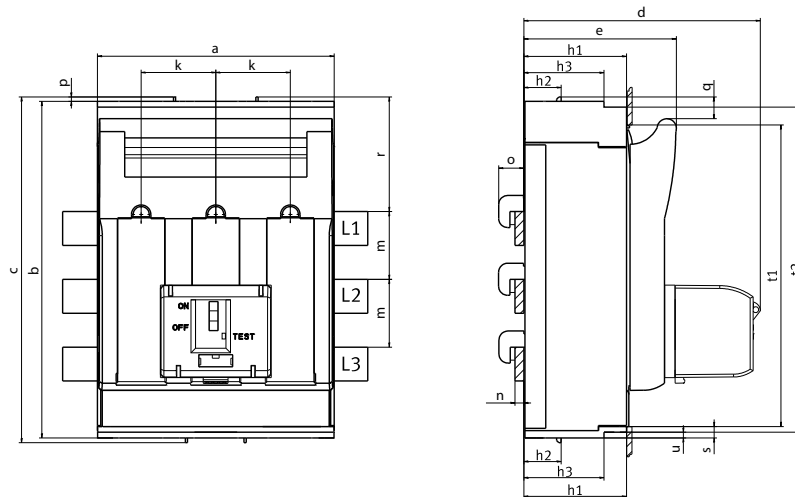

	a	b	c	d	e	h1	h2	h3	k	m	n	o	p	q	r	s
KVL-B-1 3p M10-M10 + MPFMU KVL-1 3p	184	298	306	192	117	70	32	-	58	60	4-10	25	4	19	102	5
KVL-B/FT-1 3p M10-M10 TOP + MPFMU KVL-1 3p																
KVL-B/FT-1 3p M10-M10 BOTTOM + MPFMU KVL-1 3p																
KVL-B-2 3p M10-M10 + MPFMU KVL-2 3p	210	298	306	209	135	90	32	70	66	60	4-10	25	4	19	102	10
KVL-B/FT-2 3p M10-M10 TOP + MPFMU KVL-2 3p																
KVL-B/FT-2 3p M10-M10 BOTTOM + MPFMU KVL-2 3p																
KVL-B-3 3p M10-M10 + MPFMU KVL-3 3p	250	298	306	217	143	90	32	70	82	60	4-10	25	4	19	102	10

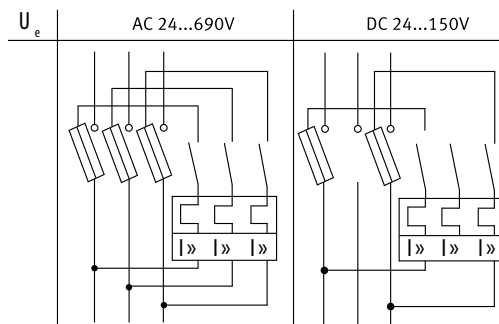



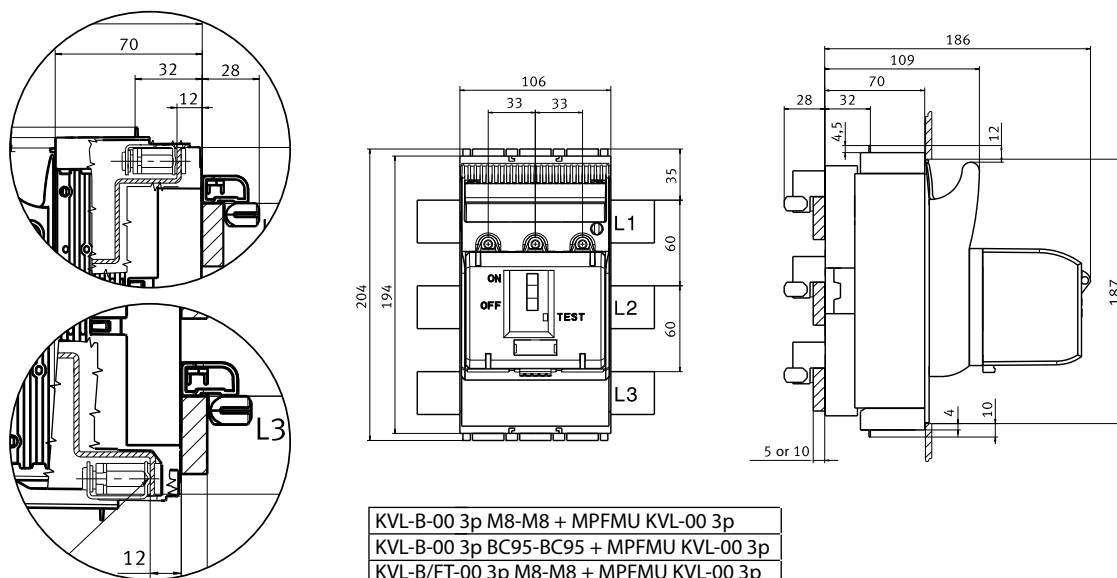

KVL-B-00 3p M8-M8 + MPF MU KVL-00 3p  
 KVL-B-00 3p BC95-BC95 + MPF MU KVL-00 3p  
 KVL-B/FT-00 3p M8-M8 + MPF MU KVL-00 3p

**Technical data (in accordance with IEC/EN 60947-3)**

Size	000				
Technical Characteristics					
Rated operational voltage	Ue	V	400 AC	500 AC	690 AC
Rated operational current	Ie	A	125	125	80
Conv. free air thermal current with fuse-links, *	Ith	A		125	
Rated frequency	f	Hz	50	50	50
Rated insulation voltage	Ui	V		800 AC	
Total power loss (without fuse)	Pv	W		12 W	
Power loss at 80% Ith (without fuse-links), **	Pv	W		8 W	
Rated impulse withstand voltage	Uimp	kV		6	
Utilisation category***			AC-22B	AC-22B	AC-21B
Rated conditional short-circuit current, ***, ****		kA	80 (500V), 80 (690V)		
Rated short-time withstand current	Icw	kA		5/1s	
Fuse links					
Size - DIN VDE 0636-2	-	-		000	
Max. rated current (gG)	In	A	125	125	125
Max. permissible power loss per fuse link	Pa	W		9	
Cable terminal					
Clamping cross-section		mm <sup>2</sup>		1,5 - 50 Cu	
Tightening torque	Ma	Nm		4,5	
Degree of Protection, front side device					
Front cover close	-	-		IP30	
Front cover open	-	-		IP10	
Operating condition					
Ambient temperature *****	Tamb	°C		-25 ... +55	
Operating condition	-	-		Continuous operation	
Mounting	-	-		vertical, horizontal	
Altitude	-	m		≤ 2000	
Pollution degree	-	-		2	
Overvoltage category	-	-		III	

\* Mounting of several units in low voltage switchgear-combinations, please think about rated diversity factors acc. to DIN EN 61439.

\*\* Reference value for replacement of devices acc. to DIN EN 61439-1 clause 10.10.4.2.

\*\*\* minimum distance to earthed, conductive parts: Lateral: 20mm/Above: 50mm

\*\*\* a) Lateral: 50mm/Above: 100mm



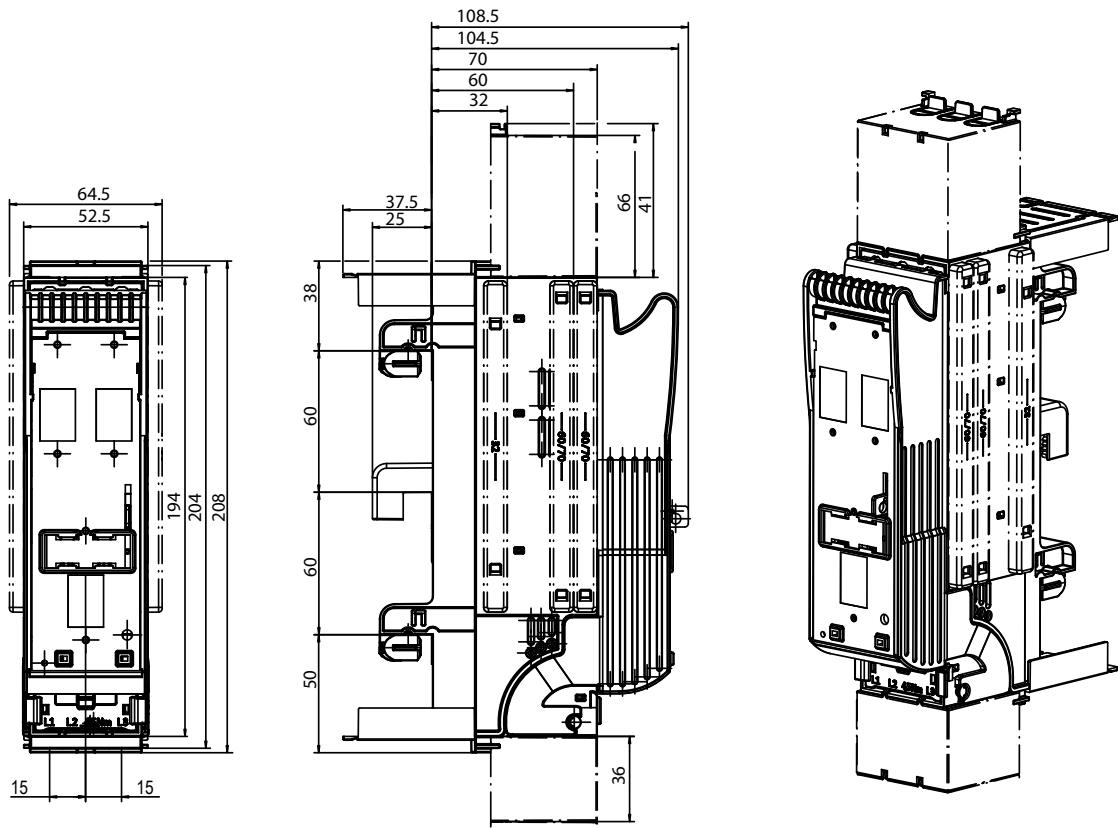

\*\*\*\* Type tested with NH fuse-links characteristic gG

\*\*\*\*\* 35°C Normal temperature, at 55°C with reduced operating current

# ETIBUSBAR / 60 mm Busbar System



KVL-B-000 3p F50 Bottom / Top

Terminal type	Type	Tightening torque	Clamping range	Size flat strip
 Screw terminal M8	F-M8x16	12 - 15 Nm	Cable lugs acc. to DIN 46234 and 46235	
 Clip terminal	S00	2,6 Nm	1,5 - 70 mm <sup>2</sup> Cu	Busbars max. 9x8 flexible flat strip max. 6x9x0,8
 Prism clamp	P0070	2,6 Nm	10 - 70 mm <sup>2</sup> Al/Cu	
 Elevator terminal	F57	2,6 Nm	1,5 - 70 mm <sup>2</sup> Cu	

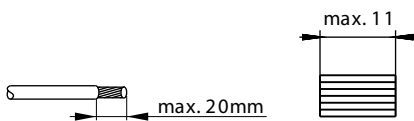

**Technical data (in accordance with IEC/EN 60947-3, VDE 0636 part 301)**

Technical Specifications		DVL-60/183	
<b>Electrical characteristics</b>			
Rated operating voltage	Ue	V	400 AC
Rated operating current	Ie	A	63
Conv. Thermal current with fuse links	Ith	A	63
Rated frequency	–	Hz	40-60
Rated insulating voltage	Ui	V	400 AC
Rated conditional short-circuit current	–	kA <sub>eff</sub>	50
Utilisation category	–	–	AC-23B
Rated making capacity	–	A	630
Rated breaking capacity	–	A	630
Rated impulse voltage	Uimp	kV	8
Electrical lifetime (switching cycles)	–	–	300
Total power dissipation (without fuse)	Pv	W	8
<b>Fuselinks</b>			
Size in according to DIN 49522, 49515	–	–	D01, D02
Max. rated current (gl/gG)	In	A	63
Max. permissible power dissipation (without fuse)	Pv	W	55
<b>Mechanical parameters</b>			
Mechanical lifetime (switching cycles)	–	–	1700
Busbar spacing (only 3-pole)	–	mm	60
Busbar thickness	–	mm	5 & 10
Busbar width	–	mm	20 & 30
<b>Cable terminal</b>			
Terminal, clamping range	–	mm <sup>2</sup>	0,75-25
<b>Degree of protection</b>			
Frontside, operating state	–	–	IP20
Front cover open	–	–	IP10
<b>Operating condition</b>			
Ambient temperature <sup>1)</sup>	Tu	°C	-25 ... 55
Operating condition	–	–	<b>Uninterrupted duty</b>
Mounting	–	–	<b>Vertical, horizontal</b>
Altitude	–	m	< 2000
Pollution degree	–	–	3
Overvoltage category	–	–	III

<sup>1)</sup> 35°C Normal temperature, 55°C with reduced current

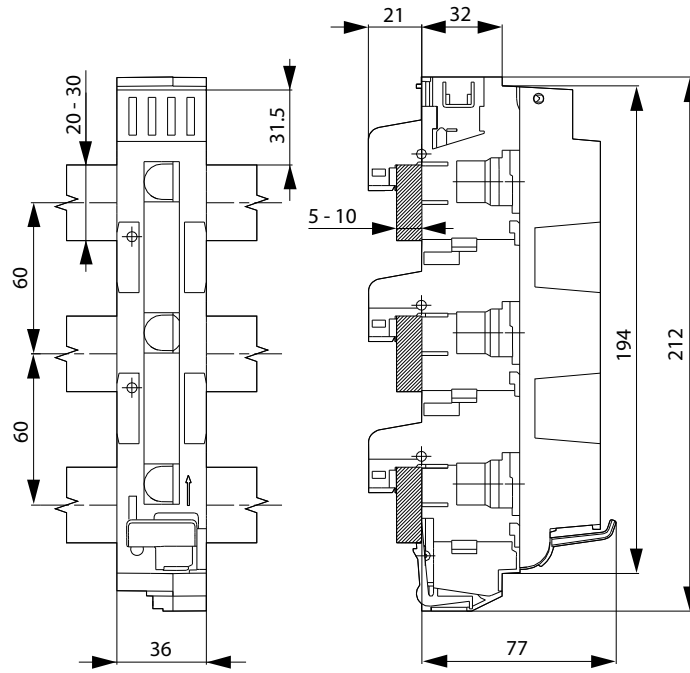

DVL-60/183

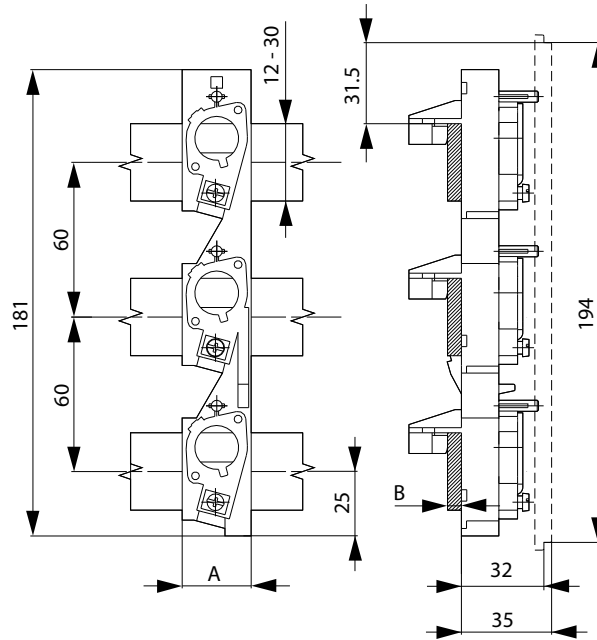

PTV-B D02-27/183-5	27	5
PTV-B DII-45/273-5	45	5
PTV-B DIII-54/333-5	54	5

PTV-B-D

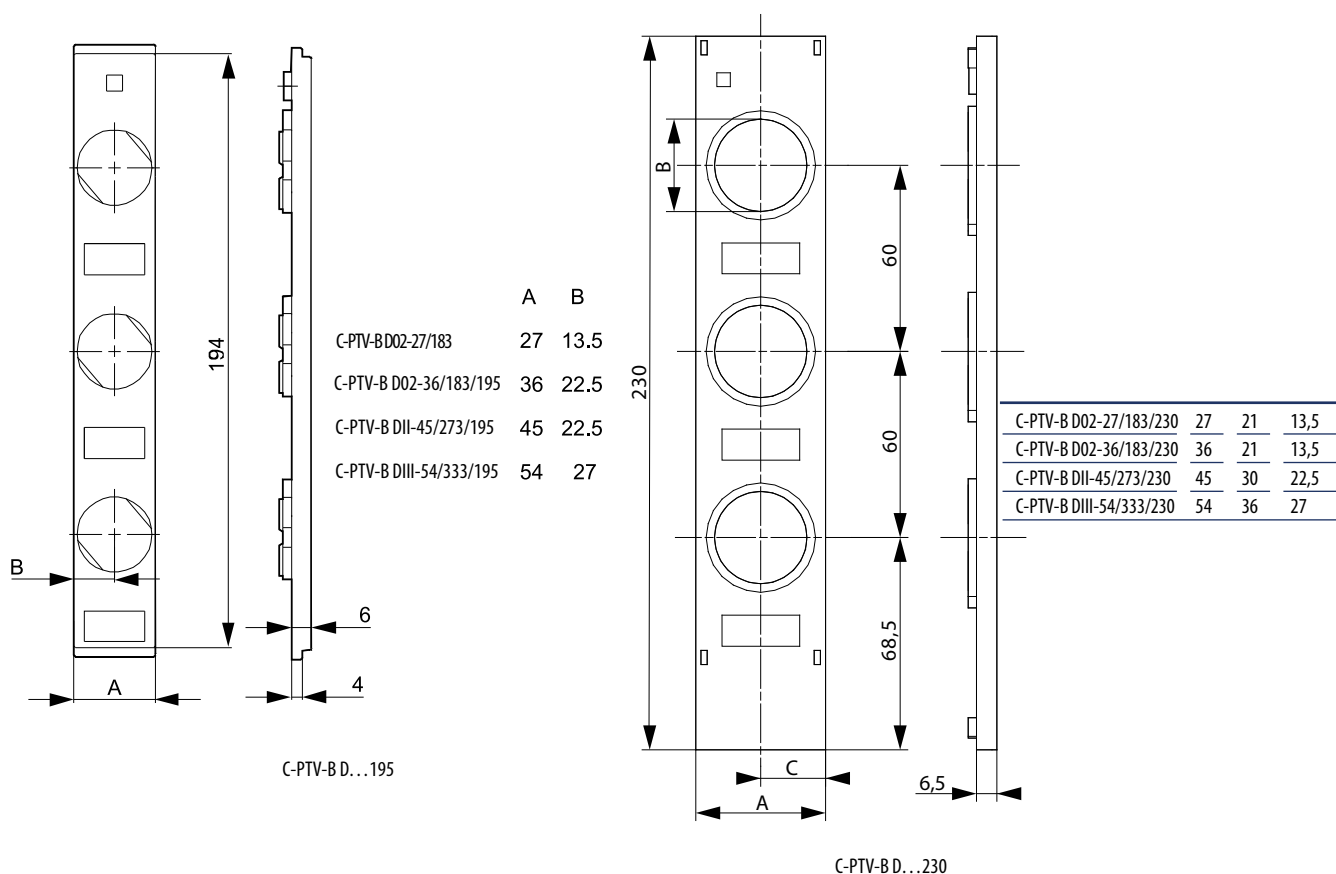

**Technical data of strip-type D-fuse bases (in according to IEC/EN 60269-1, VDE 0636 part 301)**

Technical Specifications			PTV-B D02	PTV-B DII	PTV-B DIII
<b>Electrical characteristics</b>					
Rated operating voltage	Ue	V	AC400	AC500	AC690
Rated operating current	Ie	A	63	25	63
Thermal current with fuse links	Ith	A	63	25	63
Rated frequency	–	Hz	40-60	40-60	40-60
Rated insulating voltage	Ui	V	AC400	AC500	AC690
Rated conditional short-circuit current	–	kAe	50	50	50
<b>Fuselinks</b>					
Size in according to DIN 49522, 49515	–	–	D02	DII	DIII
Max. rated current (gl/gG)	In	A	63	25	63
Max. permissible power dissipation (without fuse)	Pv	W	5,5	4	7
<b>Mechanical parameters</b>					
Busbar spacing (only 3-pole)	–	mm	60	60	60
Busbar thickness	–	mm	5 & 10	5 & 10	5 & 10
Busbar width	–	mm	12, 20, 30	12, 20, 30	12, 20, 30
<b>Cable terminal</b>					
Terminal, clamping range	–	mm <sup>2</sup>	0,75-25	0,75-25	0,75-25
<b>Degree of protection</b>					
Frontside, operating state	–	–	IP20	IP20	IP20
<b>Operating conditions</b>					
Ambient temperature <sup>1)</sup>	Tu	°C	-25 ... +55		
Operating condition	–	–	Uninterrupted duty		
Mounting	–	–	Vertical, horizontal		
Altitude	–	m	< 2000		
Pollution degree	–	–	3		
Overvoltage categorie	–	–	III		

<sup>1)</sup> 35°C Normal temperature, 55°C with reduced current

# ETIBUSBAR / 60 mm Busbar System

CL-PTV-BD/230

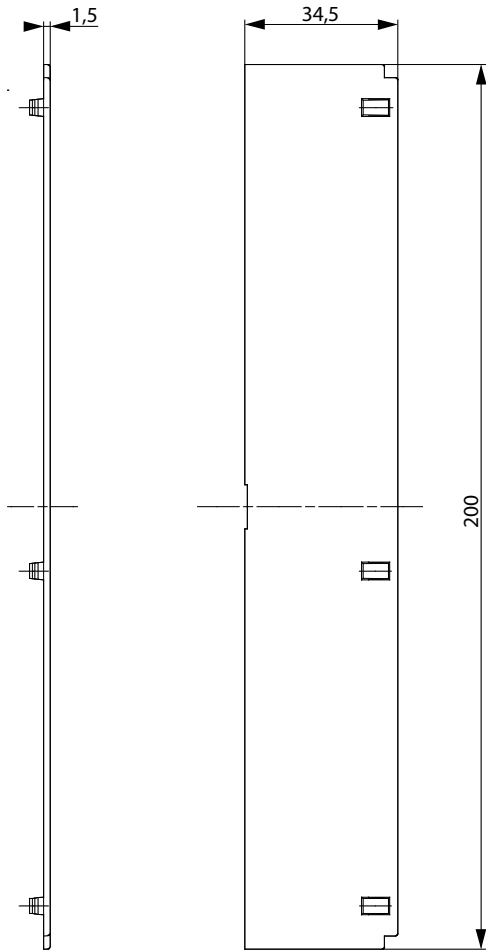
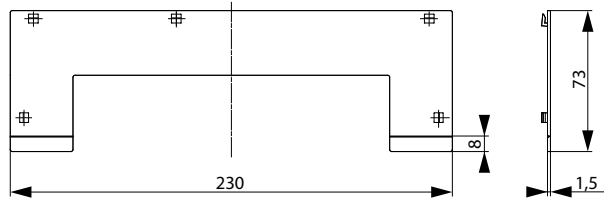

CL-PTV-BD/195

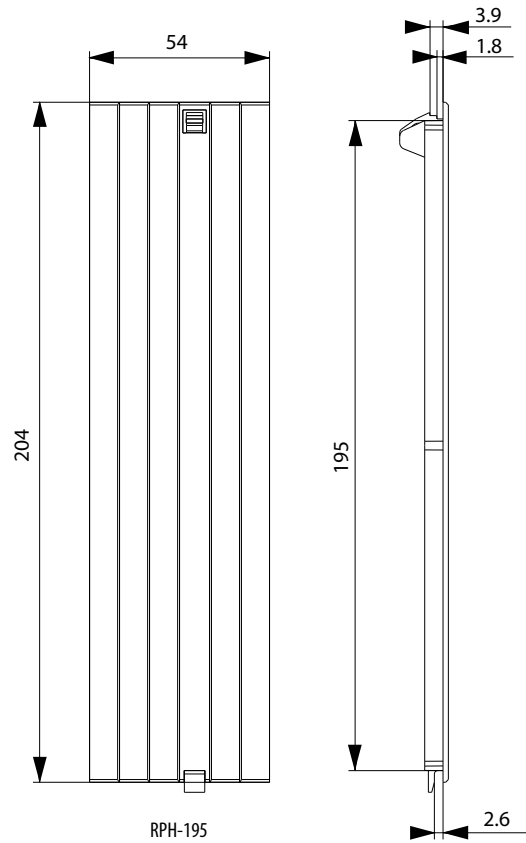

RPH-195

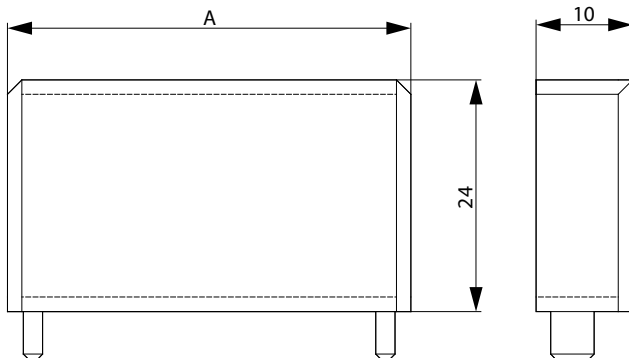

RTP-D02-27/183	27
RTP-D02-36/183	36
RTP-DII-45/273	45
RTP-DIII-54/333	54

RTP-RL/

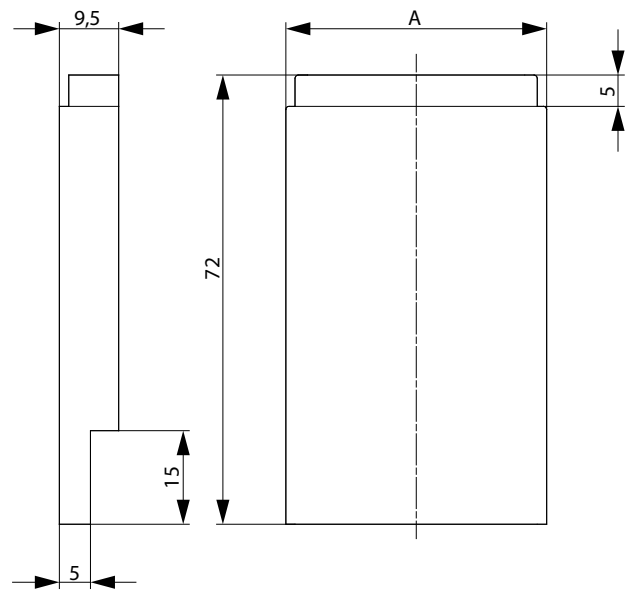

RTP-D02-27/183	27
RTP-D02-36/183	36
RTP-DII-45/273	45
RTP-DIII-54/333	54

PRS-D.../183

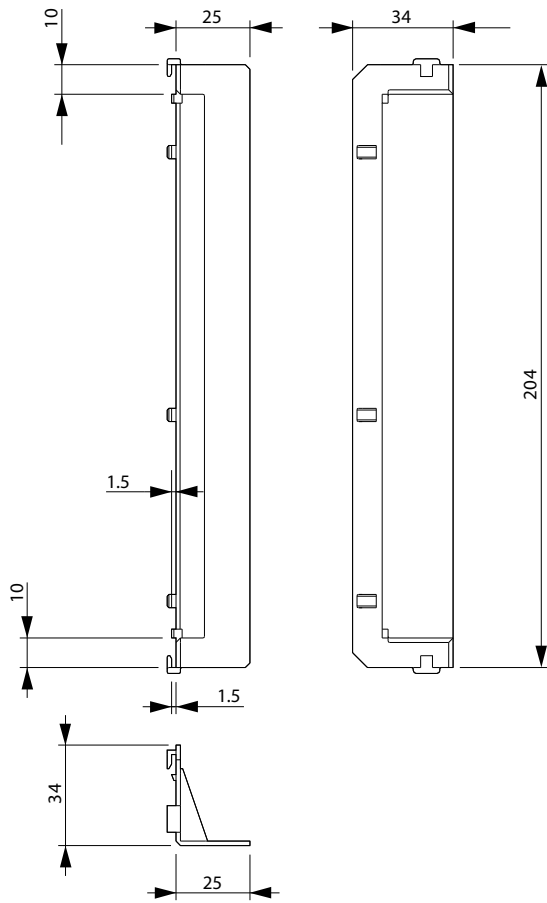

RTP-RL/230

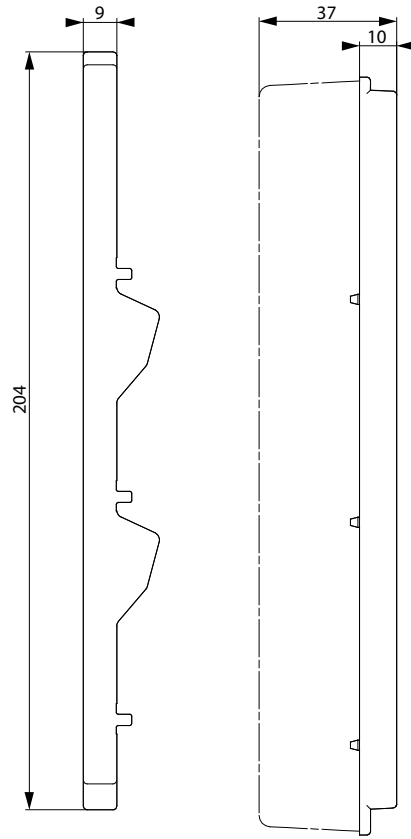

PRS-DVL

DA

# ETIBUSBAR / 60 mm Busbar System

Benefits using ETI busbar 60mm

Poor visibility of connections without orderliness links.

Reduced number of connections (less power supply terminals)

Low integration of elements

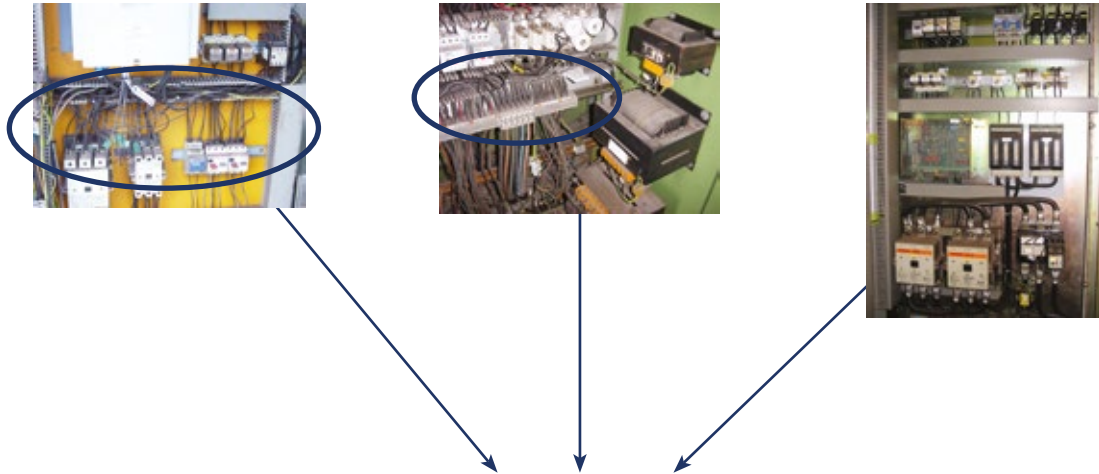

Implementation with the busbar system provides several benefits

